

# Installation Instructions



- DISCONNECT ELECTRICAL SUPPLY BEFORE INSTALLATION OR SERVICING.
- THIS PRODUCT MUST BE EARTHED.
- THIS PRODUCT IS DESIGNED TO OPERATE OUTDOORS. IF REQUIRED TO BE USED INDOORS PLEASE CONSULT DW WINDSOR.



230VAC 50Hz

## Product Details

The Strand & Ely ranges are supplied complete in a single carton.

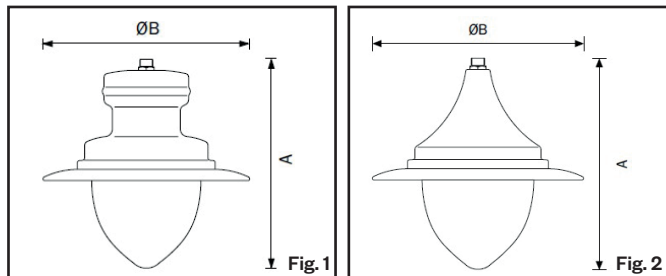

Fig. 1 - Strand lantern

Fig. 2 - Ely lantern

	Dimensions (mm)			Max. Weight (kg)	Max. Mounting Height (m)	Windage m <sup>2</sup>
	A	ØB	ØB*			
Strand / Ely A+	870	900	N/A	18.0	8	0.35
Strand / Ely A	643	670	527	11.5	8	0.19
Strand / Ely B	575	585	484	8.5	8	0.15
Strand / Ely C	498	480	396	5.5	8	0.11

Fig. 3 - Strand & Ely Data Table

\*Narrow Brim

Optics	Light Engine**					
	4 LEDs	8 LEDs	16 LEDs	24 LEDs	32 LEDs	48 LEDs
A1	1m	1.4m	2.0m	2.4m	2.7m	3.4m
A2	0.9m	1.2m	1.7m	2.1m	2.4m	3.0m
B1	1.2m	1.8m	2.5m	3.0m	3.4m	4.2m
B2	1.1m	1.5m	2.2m	2.6m	3.0m	3.7m
C2	1.0m	1.4m	2.0m	2.4m	2.7m	3.4m

Fig. 4 - Table showing the hazard distances (in metres) for different luminaires and optics within the Windsor Street.

\*\*Distances correspond to the illuminance threshold of 1240 lux in which the product's risk group assessment changes from RG2 to RG1

## Tools Required

Tools not supplied.

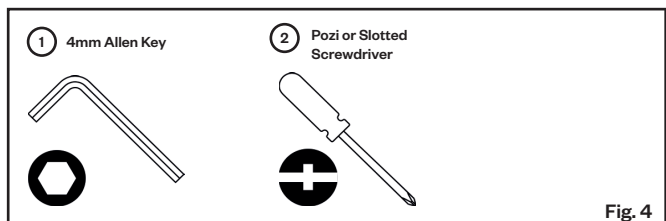

Fig. 5 - Tools required for Strand / Ely installation. Not supplied.

## Recommended Torque

	Spigot Grubscrew Torque (Nm)
Strand / Ely	10

## NOTE!

- Luminaire to be positioned so that prolonged staring into the luminaire at short distances is not expected.
- Do not stare at operating light source.
- Personnel to wear Protective Safety Glasses compliant with EN166 1F/ EN169 - 5 when commissioning or maintaining this luminaire.

## Attachment to Bracket (Easy-Fit Spigot)

### Step 1

Unpack the lantern. Feed the electrical supply cable through the bracket and through the centre hole on the spigot and into the lantern.

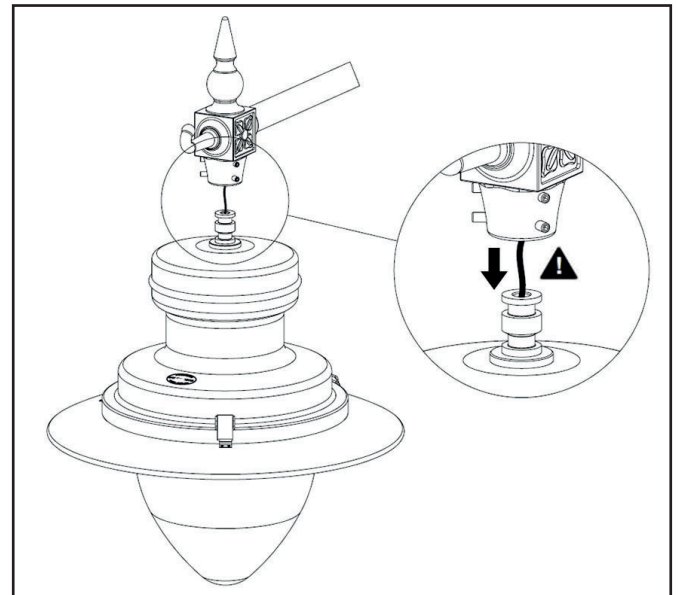

▲ Take care not to trap cable between lantern and bracket.

### Step 2

Push the spigot into the bracket and tighten the top two set screws sufficiently to hold the lantern.

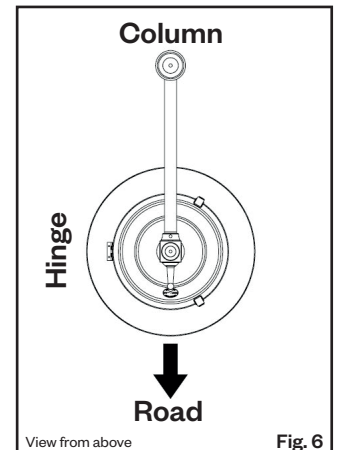
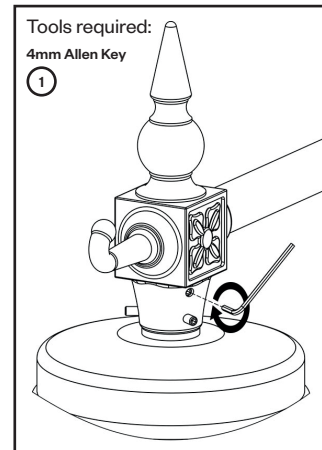

Step 3 - Rotate the lantern to align the Road Side Label with the Road

Step 4 - Tighten upper & lower grub screws fully to 10Nm torque to secure lantern.

Due to continuous product development the details within this document are subject to change at any time, please contact us for the most up-to-date information or visit: [www.dwwindsor.com](http://www.dwwindsor.com)

DW Windsor

Pindar Road, Hoddesdon, Hertfordshire, EN11 ODX

T: +44 (0) 1992 474600 | E: [info@dwwindsor.com](mailto:info@dwwindsor.com)

[dwwindsor.com](http://dwwindsor.com)

### Attachment to Bracket (1", 1¼", 1½" BSP Spigot)

#### Step 1

Unpack the lantern. Feed the electrical supply cable through the bracket and through the centre hole on the spigot and into the lantern.

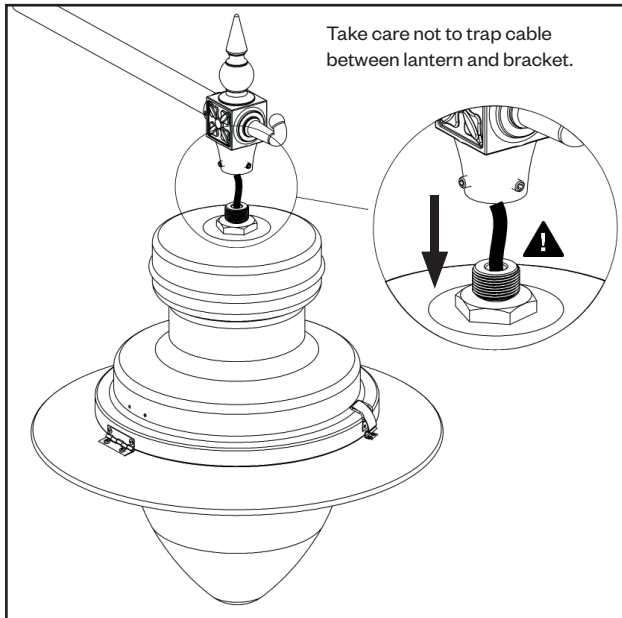

#### Step 2

Screw spigot fully into bracket, then unscrew/back off lantern just sufficiently to align Road Side Label with the Road - see Fig. 6 above.

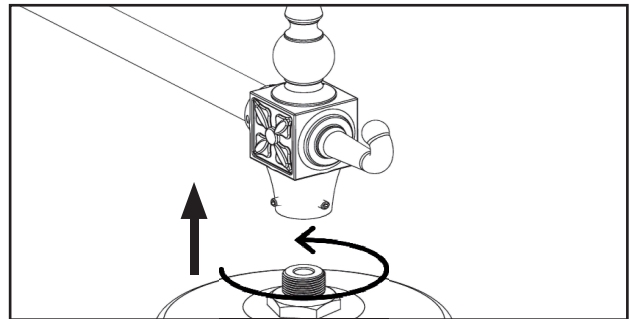

Step 3 - Tighten both grub screws to a Torque of 10Nm to secure the lantern.

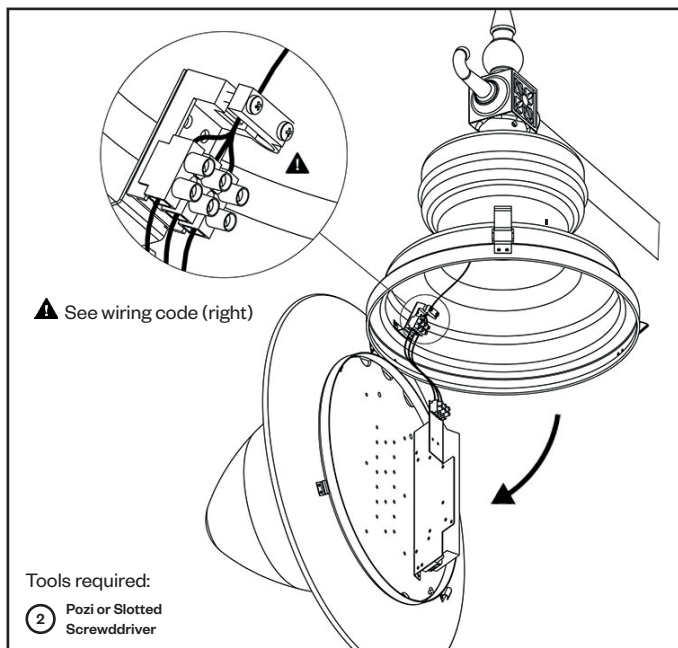
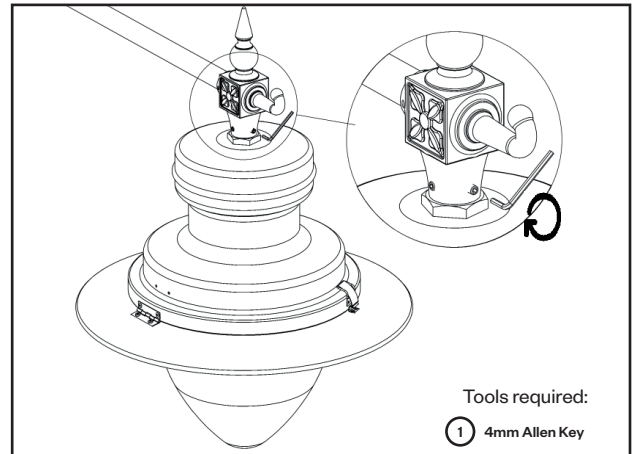

### Maintenance Access

Unclip the latches, pull the top of the latches away from the lantern, and hinge the brim down.

⚠ Caution: LOWER THE BRIM CAREFULLY.

Connect the electrical supply cable to the terminal block inside the housing.

#### Important Wiring Code

L = Live, N = Neutral, E = Earth

This lantern must be earthed.

Ensure the cable is clamped using the integral strain relief cable clamp. Hinge up the brim complete with glazing bowl and refit the latches.

### NOTE!

LEDs contained within this luminaire shall only be replaced by the manufacturer, their service agent or similar qualified person.

The Live Supply is insulated (basic) from the DALI conductor.



DW Windsor

Pindar Road, Hoddesdon, Hertfordshire, EN11 ODX

T: +44 (0) 1992 474600 | E: info@dwwindsor.com

dwwindsor.com