

**IMPORTANT: DISCONNECT ELECTRICAL SUPPLY BEFORE SERVICING
ELECTRICAL SUPPLY SEE DRIVER**



PHAROLA LED BOLLARD

These instructions are important for the safe installation of this product. Please keep them for future reference.

NOTE: This product is a CLASS 1 luminaire and must be earthed at all times.

This product can be specified with an integral root, flange plate or buried flange plate. An additional first fix ground root can also be supplied with the buried ground root. Refer to the manufacturer for further details.

BOLLARD INSTALLATION

Only the first fix ground root is designed to accept armoured cable.

If not using the first fix ground root variant make the mains connection in an appropriate sized IP68 enclosure. Install the IP68 enclosure to the manufactures instructions in a sufficient size pit with adequate drainage. See Fig. 1 for details. Protect bollard cable in ground with conduit.

IMPORTANT WIRING CODE

**L=LIVE (BROWN), N=NEUTRAL (BLUE),
E=EARTH (YELLOW & GREEN)**

Flange Mount:

Assemble the bollard base directly to the foundations using the four fixings holes on the flange plate. See table & Fig. 2 for details. Check orientation of head and secure with M12 anchor bolts. Please observe connection details stated above. Mains cable 1.1m in length.

Buried Flange Mount:

Assemble the bollard base directly to the foundations using the four fixings holes on the flange plate. See table & Fig. 2 for details. Observing the correct bollard height and head orientation, secure with M12 anchor bolts. Please observe connection details stated above. Mains cable 0.9m in length.

Integral Root Mount:

Assemble anti-lift out bar centrally in root with M10 nuts positioned on the inside. Install bollard in ground observing the correct bollard height and head orientation. See table & Fig. 2 for details. Please observe connection details stated above. Mains cable 0.8m in length.

FIG. 1

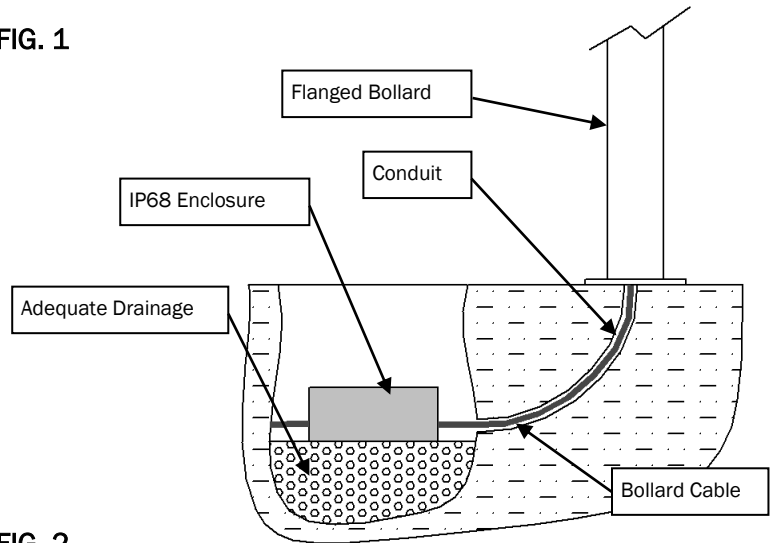
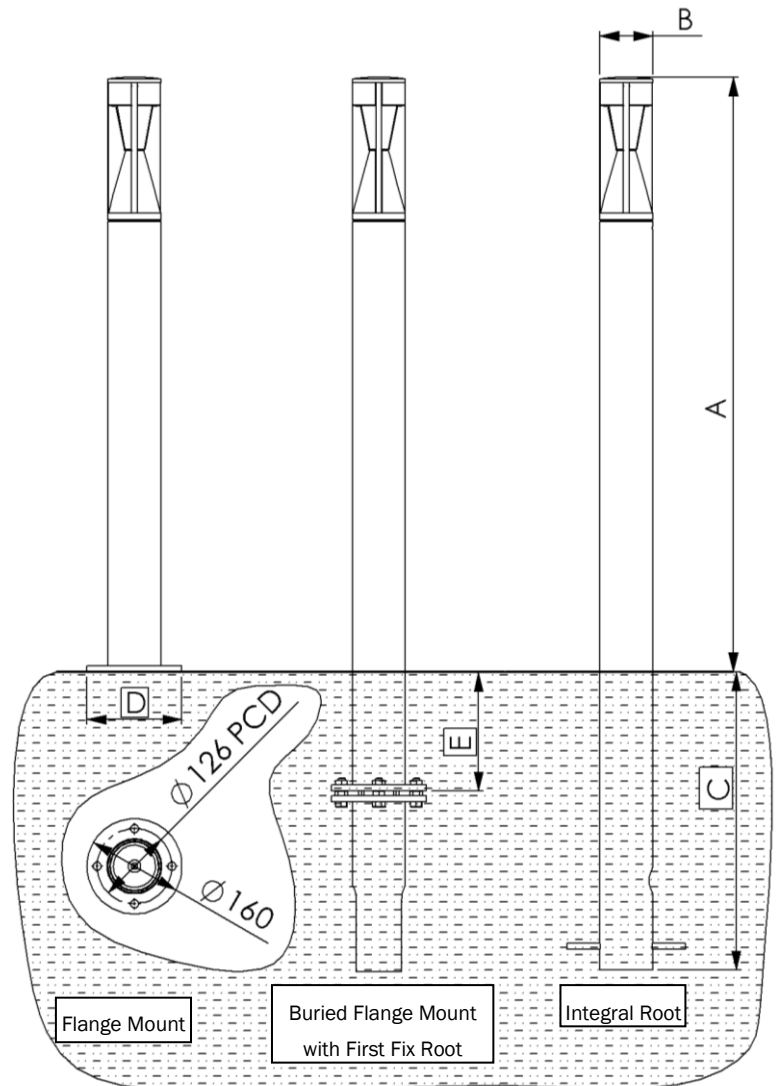

FIG. 2



DW Windsor Lighting

Pindar Road, Hoddesdon, Hertfordshire, EN11 0DX

Tel: 01992 474600 Fax: 01992 474601

Email: info@dwwindsor.co.uk

www.dwwindsor.co.uk

First Fix Root:

Install First Fix Root in foundation observing the correct bollard height and head orientation. See table and Fig 2 for details.

Pass armoured cable (6mm² Max) through root (Fig 3) and install into supplied earthing bracket as shown in Fig 5. Terminate earth cable to bracket earth terminal. Terminate live and neutral cables in terminal block observing polarity as shown in Fig 4.

Wire bollard cable into 3 pole plug observing polarity as shown on plug.

Fit plug into socket and check for continuity.

Place bollard over the First Fix Root and orientate onto bolts.

Fit all four M12 nuts.

Complete ground work to the correct bollard height.

Driver Maintenance:

IMPORTANT: Disconnect the electrical supply before servicing.

Please ensure if security grub screw is removed, that silicon grease is applied before refitting to avoid it locking in position.

To maintain IP65 Rating gland and all fixings must be kept fully tightened.

To access the driver compartment the bollard head must be removed as shown in fig 6.

Using a security key loosen the grub screw by turning anticlockwise.

Twist bollard head anticlockwise by 45° and lift up to reveal LED driver.

To refit head repeat the above instructions in reverse. To prevent vandalism the security grub screw must be tightened fully.

Cleaning:

Clean glazing and bollard using soapy water and a lint free cloth.

Care must be taken when cleaning glazing as scratches will affect performance.

FIG. 3

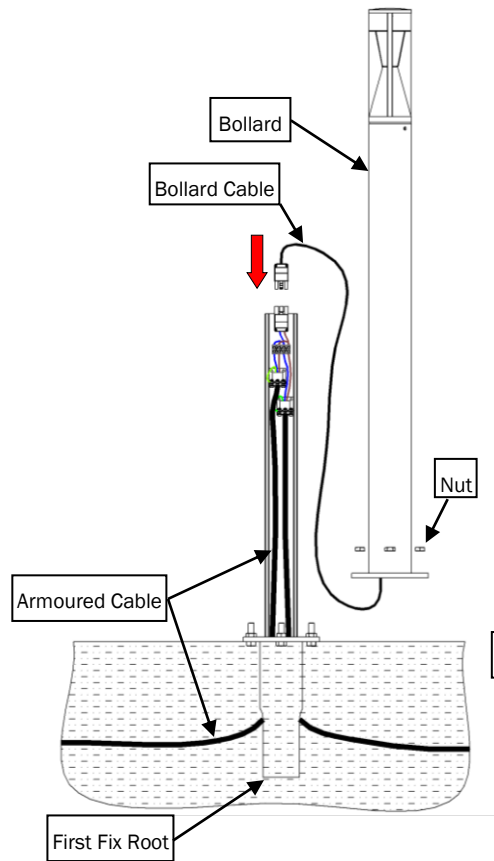

FIG. 6

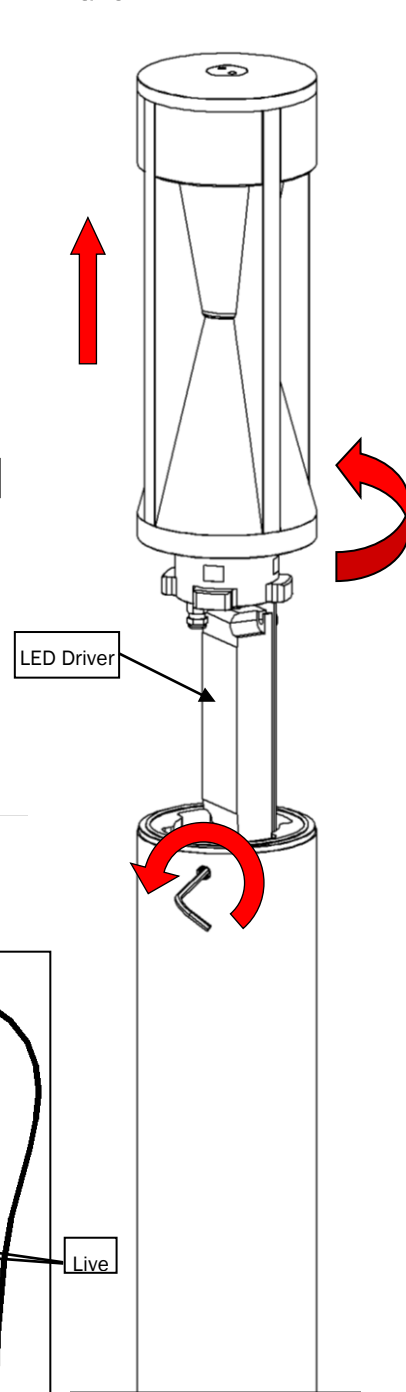

FIG. 4

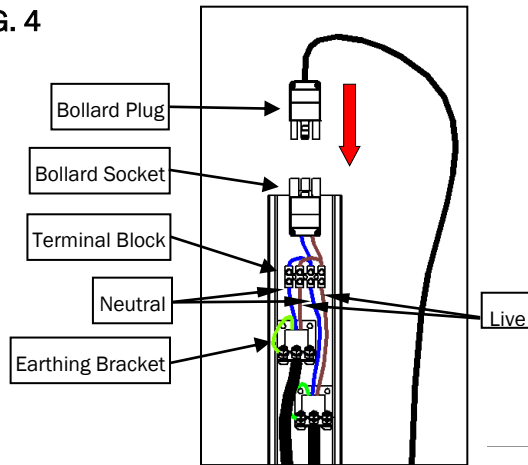
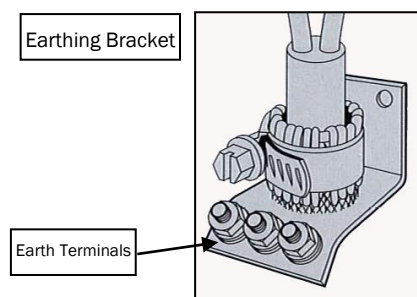

FIG. 5



Variant	Dimensions (mm)					Weight (kg)
	A	B	C	D	E	
Standard Root	2200	89	500			21
	1000	89	500			13
	600	89	300			9
Standard Flange	2200	89		160		19
	1000	89		160		8
	600	89		160		11
Buried Flange	2200	89		160	200	20
	1000	89		160	200	9.5
	600	89		160	200	12
First Fix	2200	89	500	160	200	26.5
	1000	89	500	160	200	18.5



DW Windsor Lighting
 Pindar Road, Hoddesdon, Hertfordshire, EN11 ODX
 Tel: 01992 474600 Fax: 01992 474601
 Email: info@dwwindsor.co.uk
 www.dwwindsor.co.uk