

Installation Instruction



IP66* IK08**
230VAC 50Hz



IMPORTANT

10/630/06 REV B

- DISCONNECT ELECTRICAL SUPPLY BEFORE INSTALLATION OR SERVICING.
- THIS PRODUCT MUST BE EARTHED.
- THIS PRODUCT IS DESIGNED TO OPERATE OUTDOORS.
- THIS PRODUCT CONTAINS A LIGHT SOURCE OF ENERGY EFFICIENCY C TO F. THIS IS DEPENDANT ON PRODUCT DRIVE CURRENT, LED COLOUR TEMPERATURE & OPTIC.
- DO NOT STARE AT THE OPERATING LIGHT SOURCE.
- PERSONNEL TO WEAR PROTECTIVE SAFETY GLASSES COMPLIANT WITH EN166 1F/EN169-5 WHEN COMMISSIONING OR MAINTAINING THIS PRODUCT.
- BASIC INSULATION IS PROVIDED BETWEEN POWER & DALI.
- ALWAYS MAINTAIN BASIC INSULATION BETWEEN LOW VOLTAGE SUPPLY AND CONTROL.
- LEDS CONTAINED WITHIN THIS LUMINAIRE SHALL ONLY BE REPLACED BY THE MANUFACTURER, THEIR SERVICE AGENT OR SIMILAR QUALIFIED PERSON.
- THE LUMINAIRE SHOULD BE POSITIONED SO THAT PROLONGED STARING INTO THE LUMINAIRE AT A DISTANCE CLOSER THAN 2.7 METERS IS NOT EXPECTED.

PRODUCT DETAILS

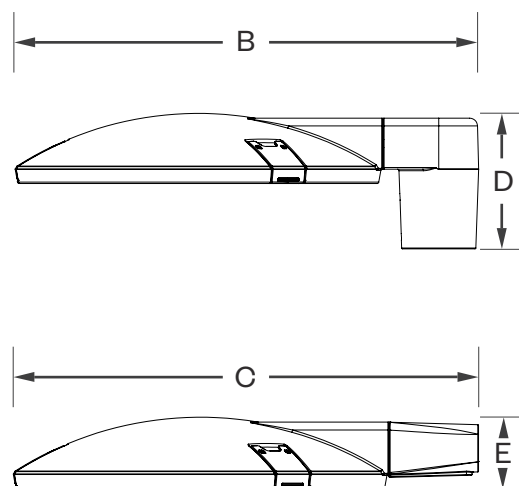
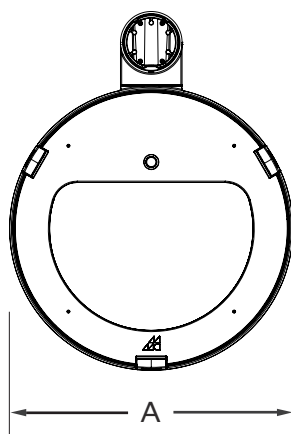
| | DAYTONA 450 | DAYTONA 500 |
|---|----------------|----------------|
| WINDAGE (m ²)  | 0.043 | 0.065 |
| WEIGHT (kg)  | 8.5 kg | 13.5 kg |
| A (mm) | 460 | 580 |
| B (mm) | 582 | 700 |
| C (mm) | 572 | 690 |
| D (mm) | 170 | 193 |
| E (mm) | 88 | 110 |



* IP66 - FOR GEAR COMPARTMENT & LIGHT ENGINE
IP65 - CONTROLS & PHOTOCELLS

** IK10 FOR POLYCARBONATE LENS VERSION

TOOLS REQUIRED

Tools not supplied unless otherwise stated.

① TORQUE WRENCH

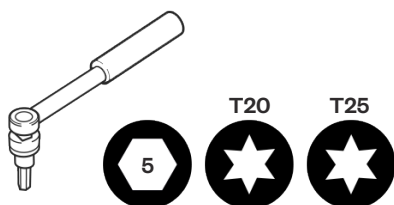

② SLOT HEAD
SCREWDRIVER

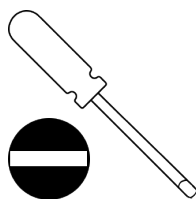

③ 24mm A/F
SPANNER

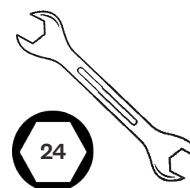

WIRING (NON PRE-CABLED VERSION)

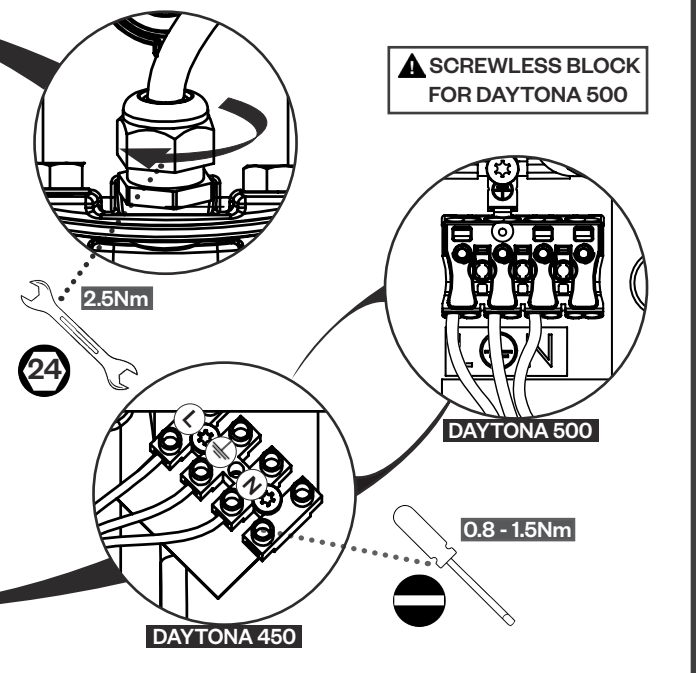
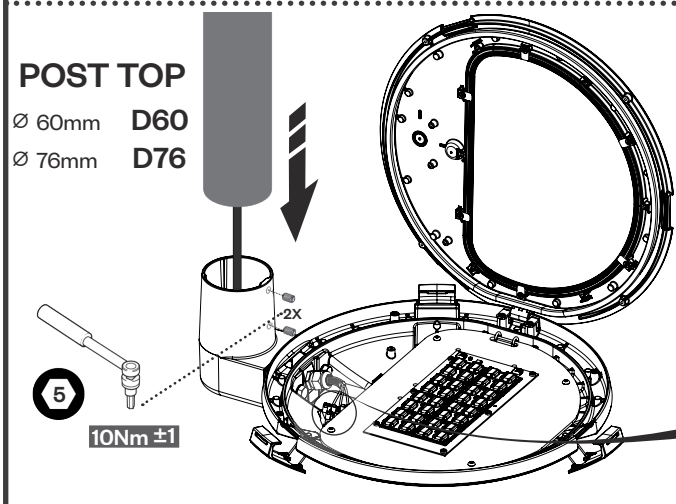
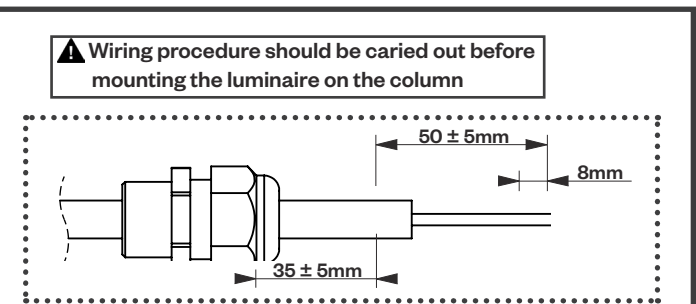
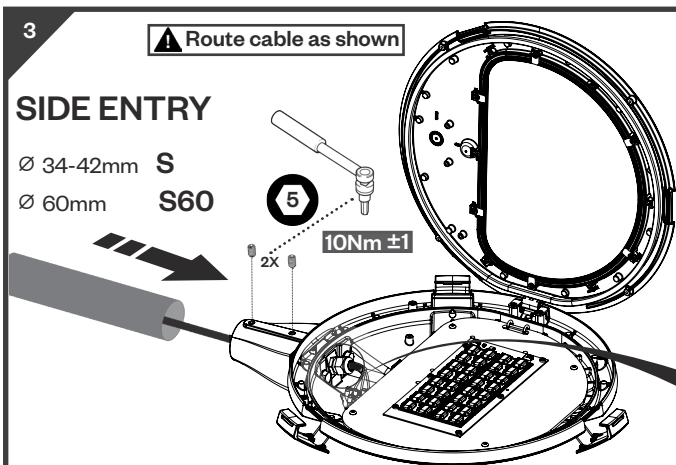
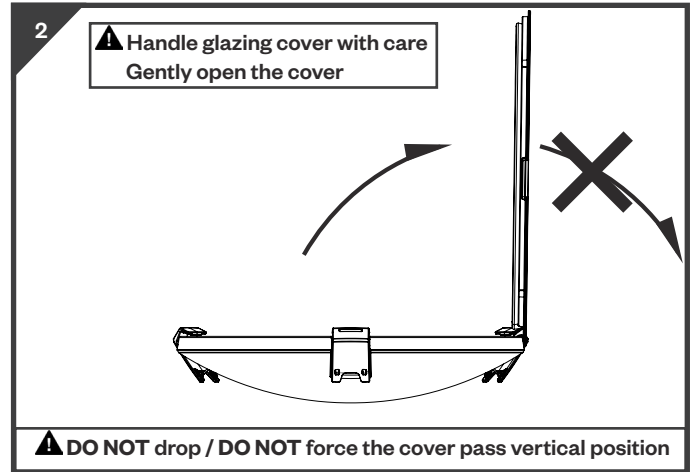
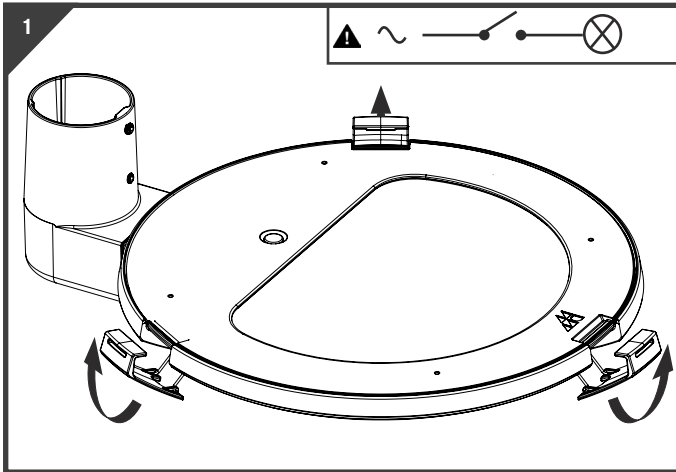

LIGHT ENGINE & GEAR TRAY REPLACEMENT

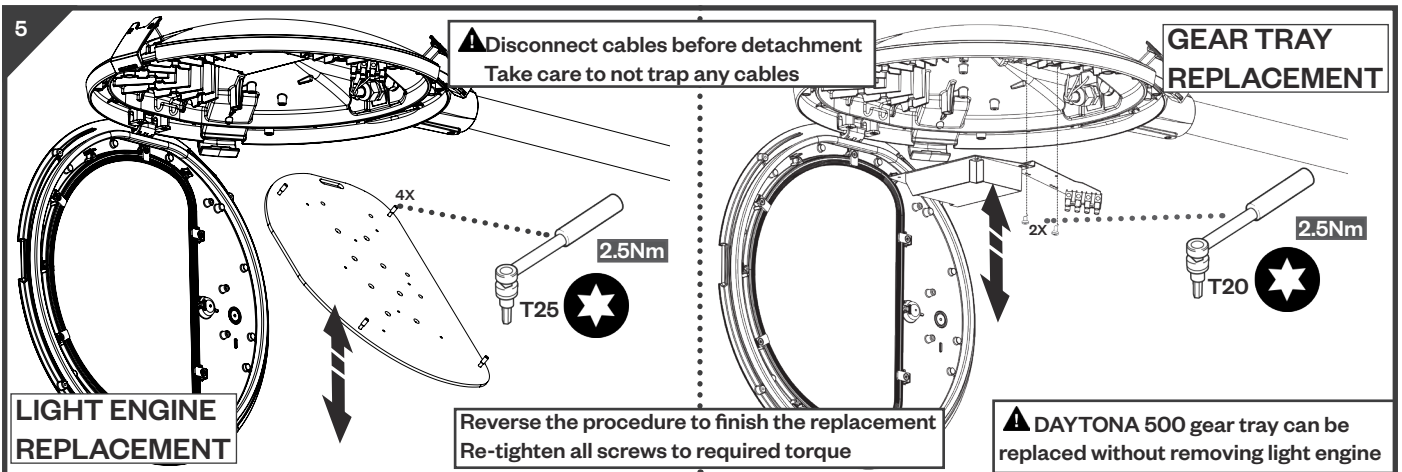
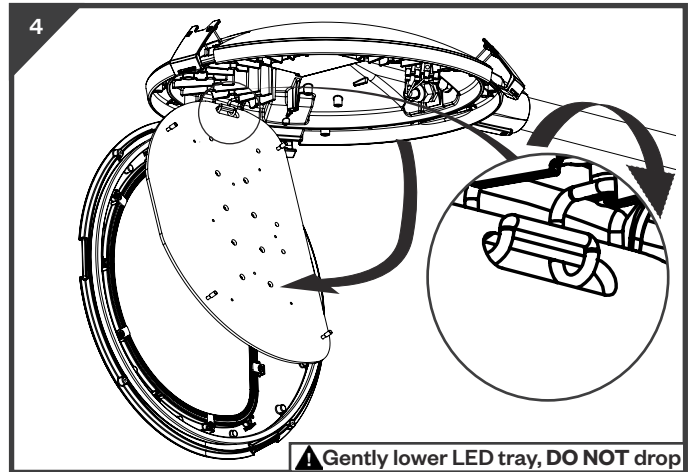
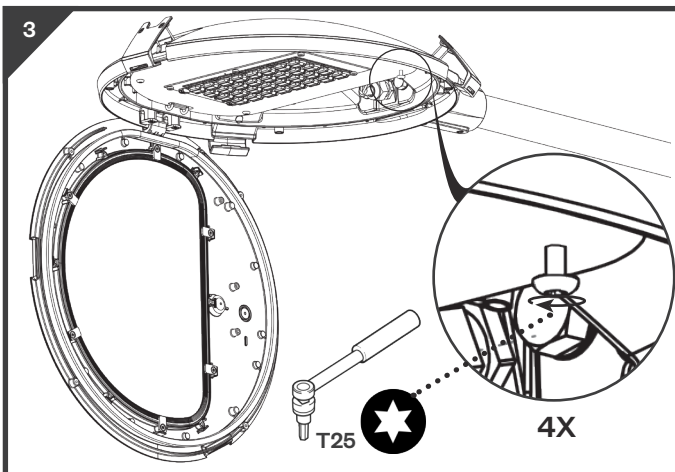
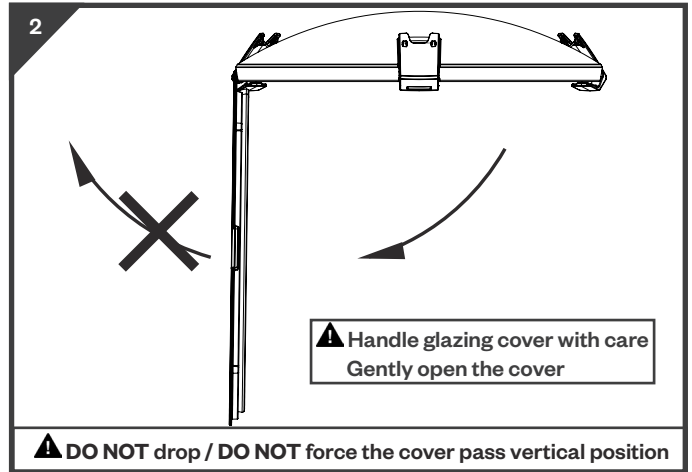
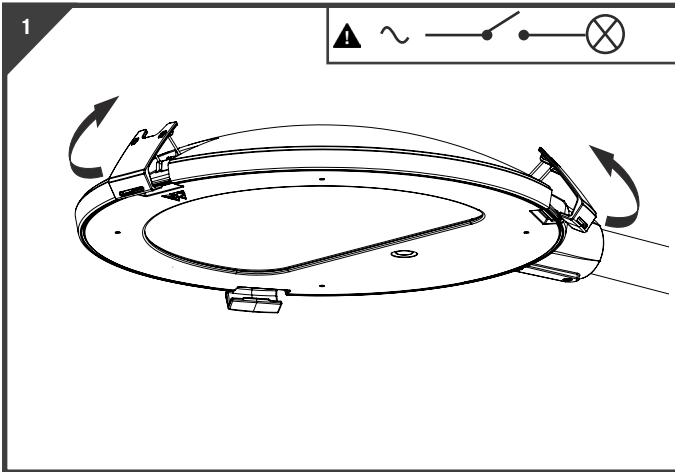

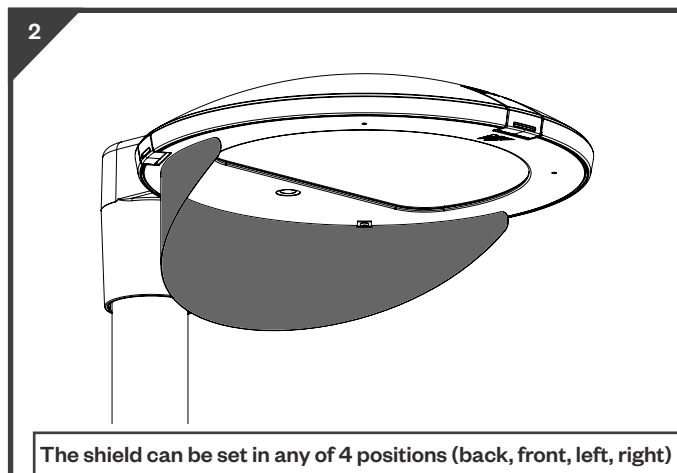
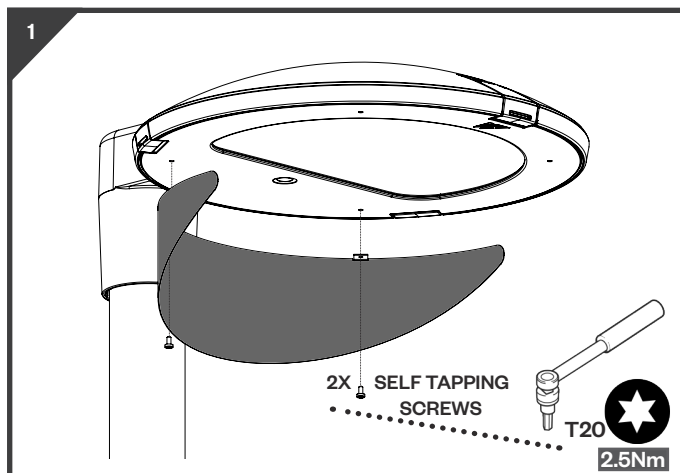
LIGHT SHIELD INSTALLATION

CLEANING

The luminaire is protected against water ingress to IP66.

Sealed design ensures that this rating will be maintained over the full lifetime of the product.



Over time with exposure to the elements, the painted exterior of this luminaire may show signs of weathering such as loss of gloss, chalking and slight colour change.

A simple regular clean will minimise the effects of weathering and will remove dirt, grime and other build-up detrimental to all surface coatings.

Use a solution of warm water and non-abrasive, pH neutral detergent solution. Surfaces should be thoroughly rinsed after cleaning to remove all residues. Cleaning should be carried out by hand using a soft cloth or sponge.

DO NOT use high pressure water jets or high-pressure cleaners.

CLEANING FREQUENCY

products installed within:

500m of the coast: 3 months

500m – 2000m of the coast or estuary: 6 months

Greater than 2000m of the coast: 12 months

SUPPORT TAG

During installation, remove the label from luminaire glazing and attach inside the column base using cable ties.

Luminaire Information can be acquired during future maintenance by scanning the label with mobile devices.

