

Installation Instructions



IP66

IK08*

230VAC 50Hz



IMPORTANT

- DISCONNECT ELECTRICAL SUPPLY BEFORE INSTALLATION OR SERVICING.
- THIS PRODUCT MUST BE EARTHED.
- THIS PRODUCT IS DESIGNED TO OPERATE OUTDOORS.
- THIS PRODUCT CONTAINS A LIGHT SOURCE OF ENERGY EFFICIENCY CLASS C TO F, THIS IS DEPENDENT ON PRODUCT DRIVE CURRENT AND LED COLOUR TEMPERATURE
- DO NOT STARE AT OPERATING LIGHT SOURCE.
- PERSONNEL TO WEAR PROTECTIVE SAFETY GLASS COMPLIANT WITH EN166 1F/EN169-5 WHEN COMMISSIONING OR MAINTAINING THIS LUMINAIRE.
- BASIC INSULATION IS PROVIDED BETWEEN POWER & DALI.
- ALWAYS MAINTAIN BASIC INSULATION BETWEEN LOW VOLTAGE SUPPLY AND CONTROL.
- LEDS CONTAINED WITHIN THIS LUMINAIRE SHALL ONLY BE REPLACED BY THE MANUFACTURER, THEIR SERVICE AGENT OR SIMILAR QUALIFIED PERSON.
- THE LUMINAIRE SHOULD BE POSITIONED SO THAT PROLONGED STARING INTO THE LUMINAIRE AT A DISTANCE CLOSER THAN 2.7 METERS IS NOT EXPECTED.

* IK10 FOR POLYCARBONATE LENS VERSION

PRODUCT DETAILS

	DAYTONA
Windage 	0.052 m ²
Windage(CxS)	0.027 m ²
Weight 	8.5 kg

UNIT: mm

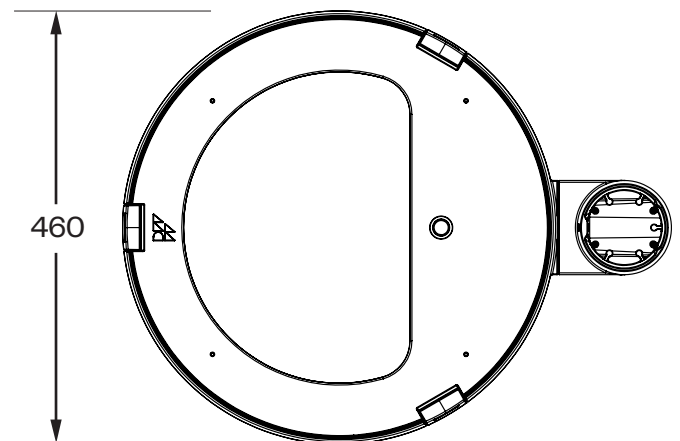
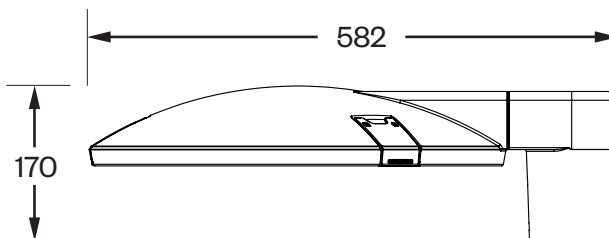
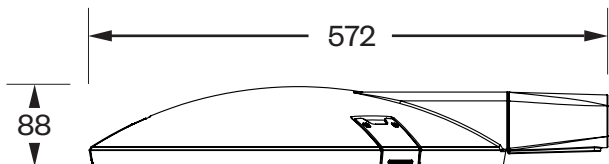

TOOLS REQUIRED

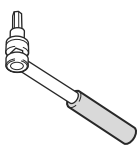

TORQUE DRIVER



T20



T25

FOR LED & GEAR TRAY REPLACEMENT



SLOTTED SCREWDRIVER



SPANNER

24mm

PRE-WIRED VERSION

SIDE ENTRY

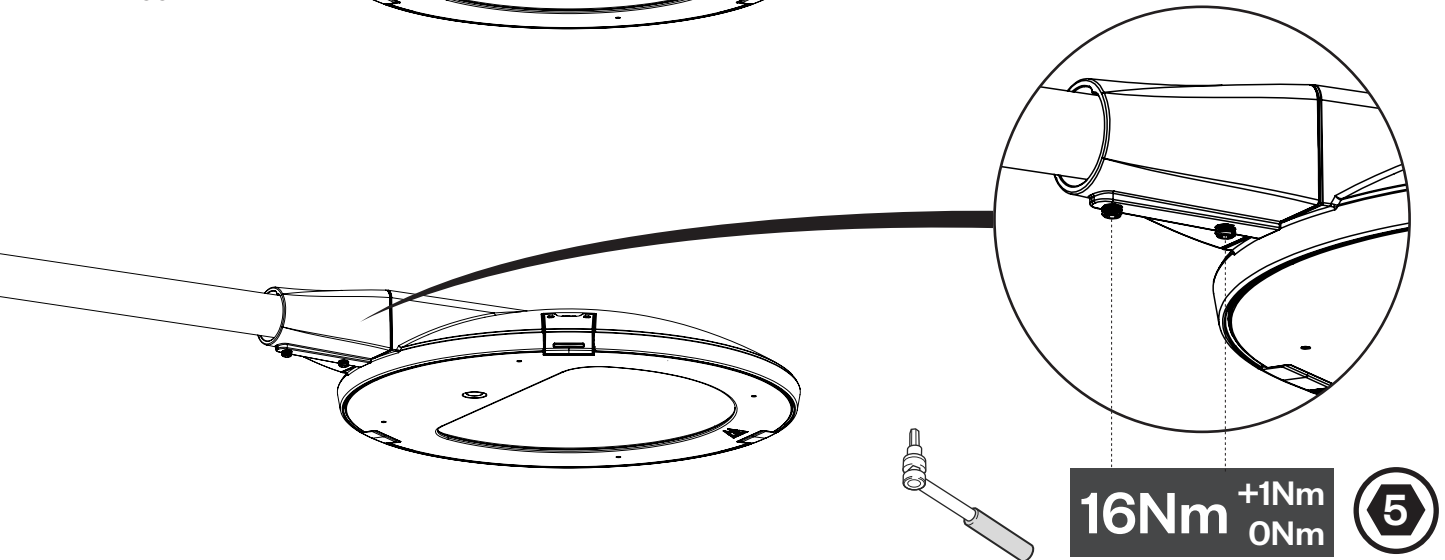
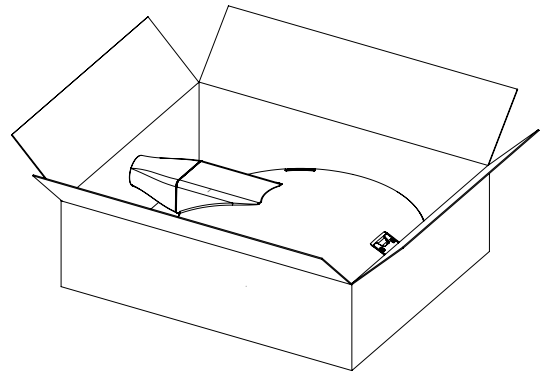
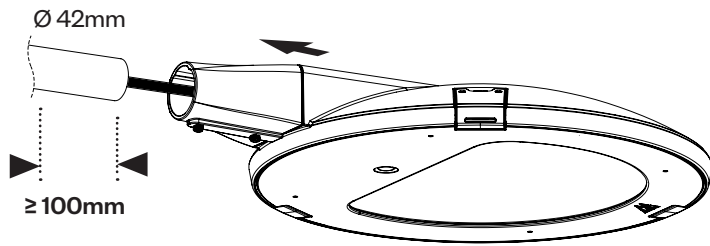

TOP ENTRY

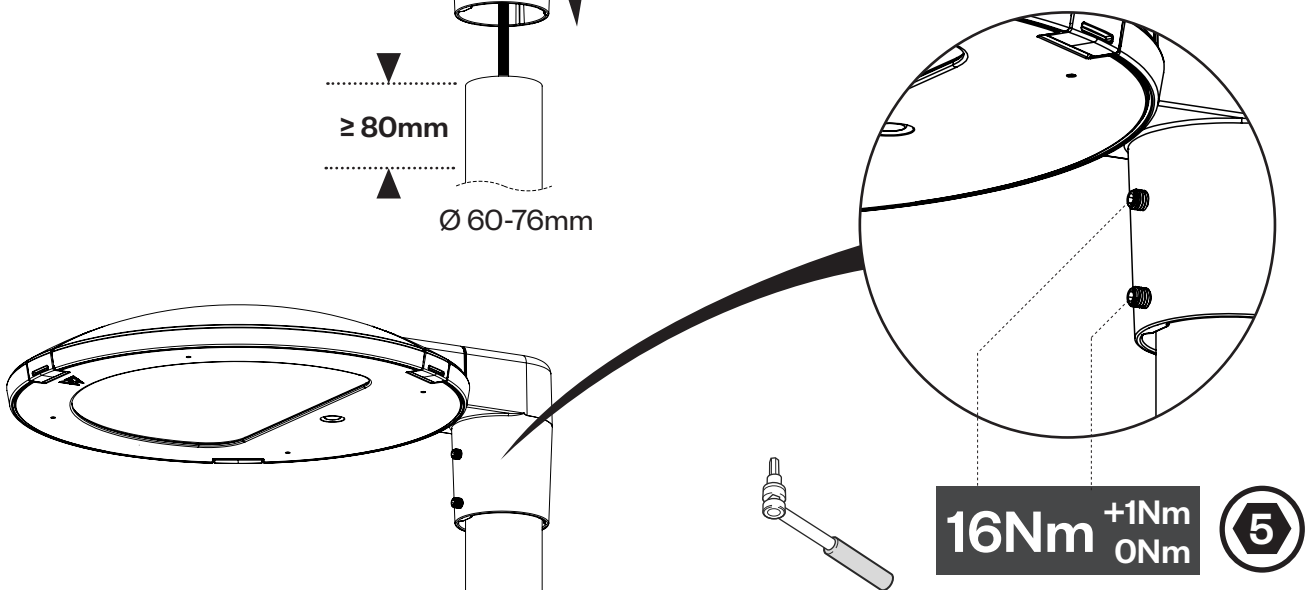
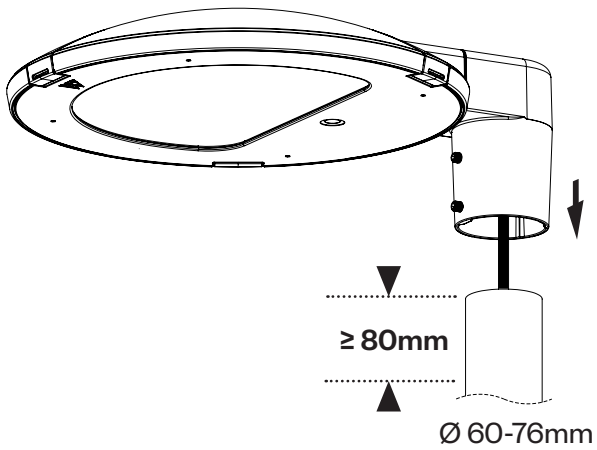

NON PRE-WIRED VERSION

 Wiring procedure should be carry out before mounting the luminaire on the column

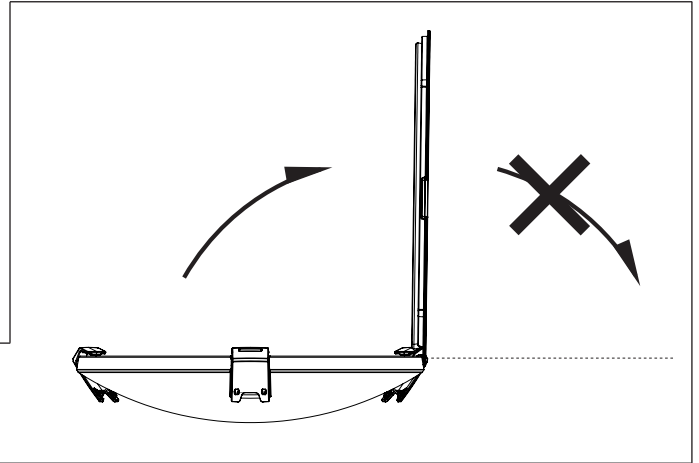
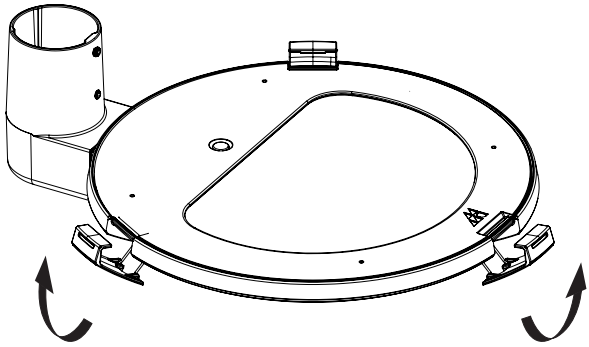
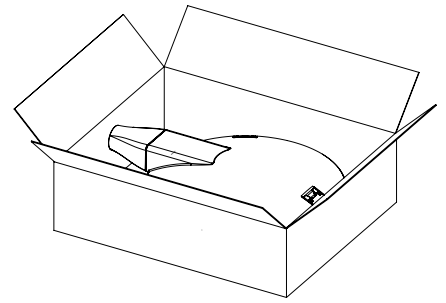

 Handle glazing cover with care
Gently open the cover, DO NOT drop
DO NOT force the cover pass vertical position

TOP ENTRY

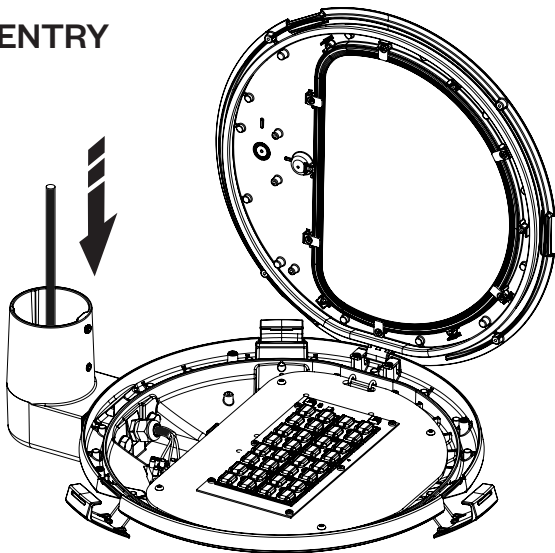

SIDE ENTRY

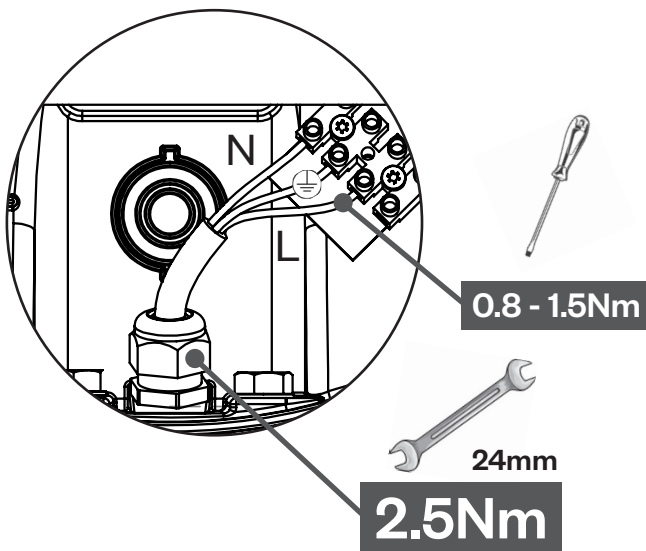
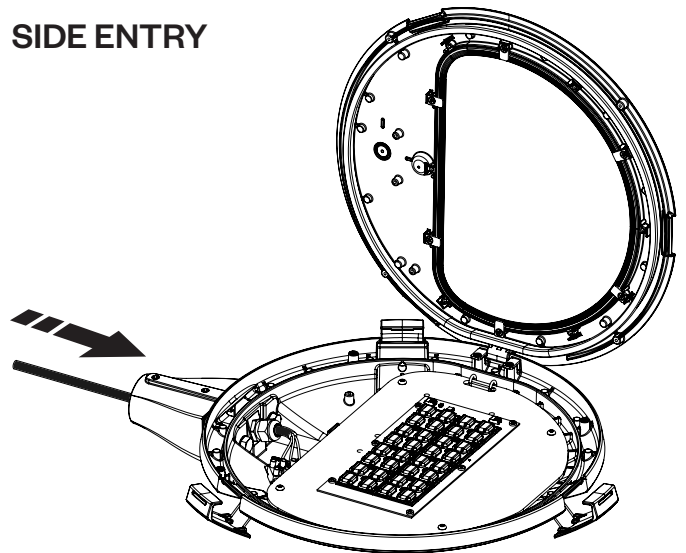

Unit: mm

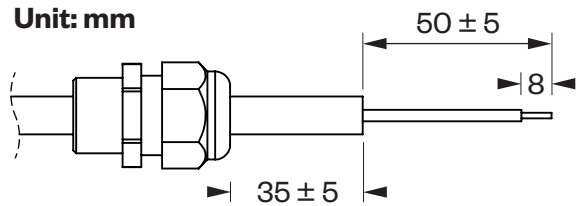

 Take care to not trap any cables when closing the product

LIGHT ENGINE & GEAR TRAY REPLACEMENT

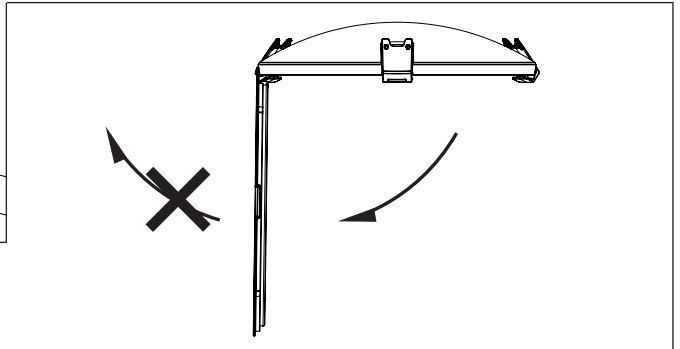
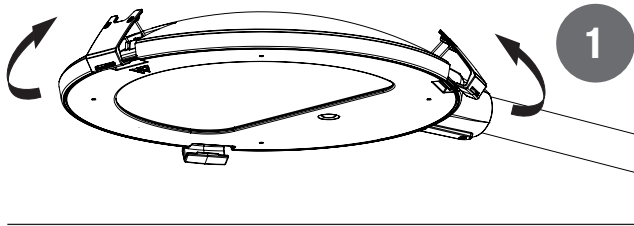

! Handle glazing cover with care
Gently lower the cover, **DO NOT** drop
DO NOT force the cover pass vertical position

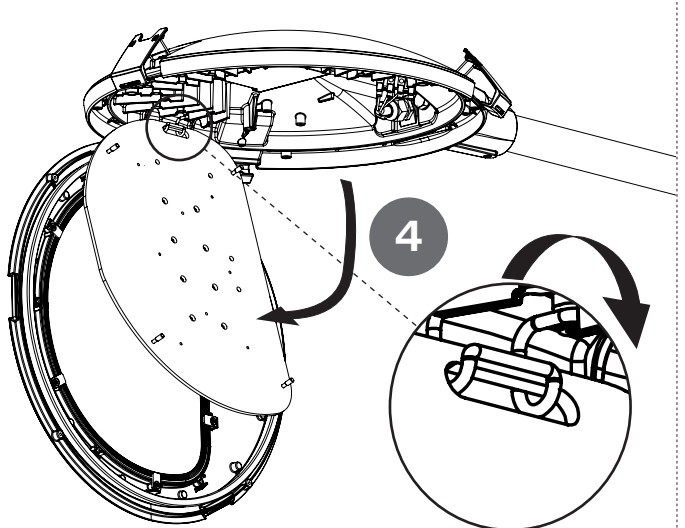
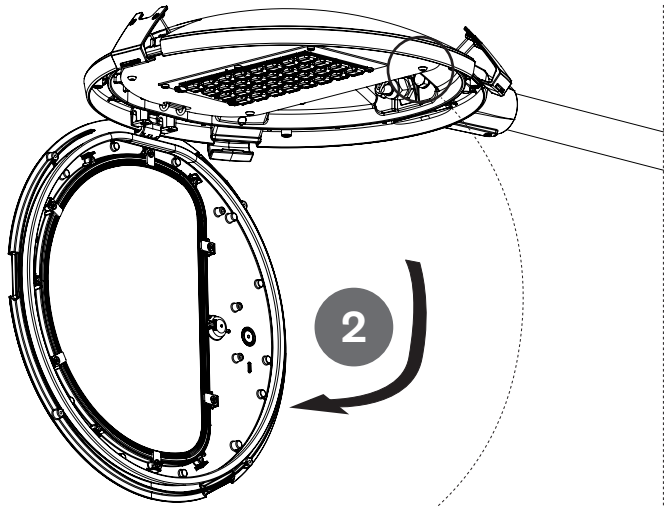

! Gently lower LED tray, **DO NOT** drop
Disconnect LED power cables before detachment

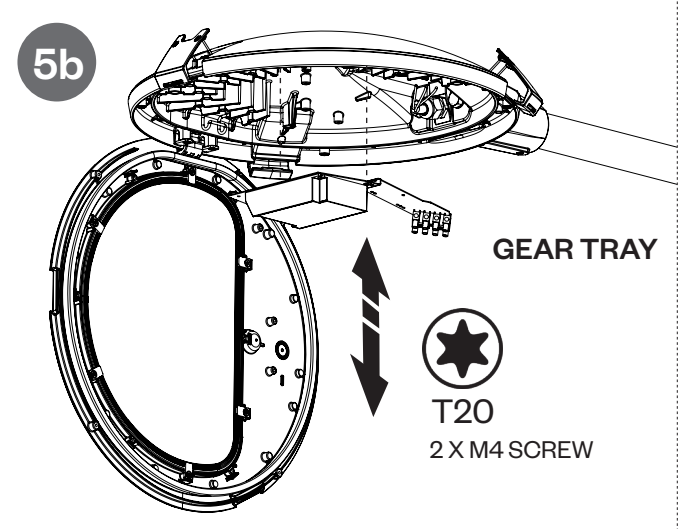
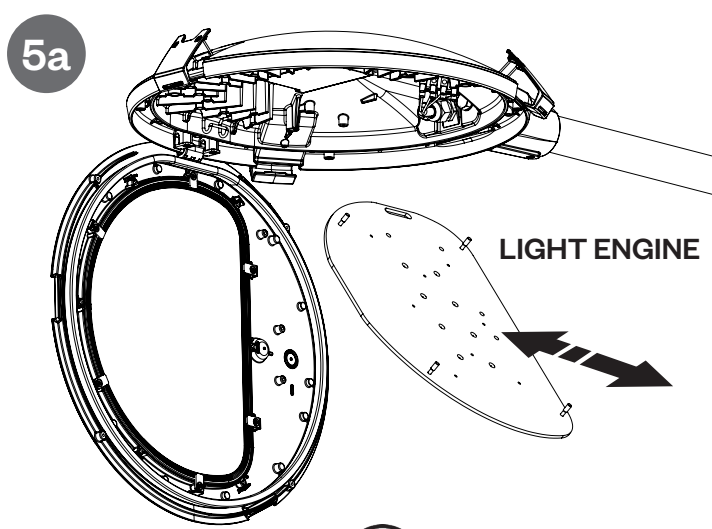
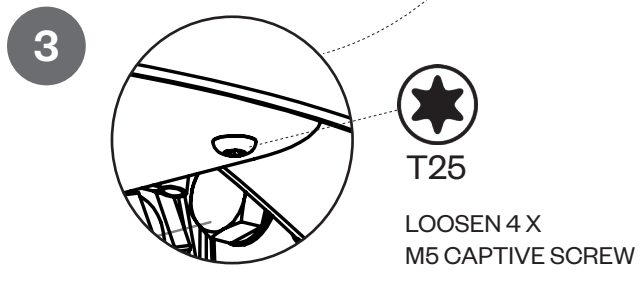

T25
2.5Nm

T20
2 X M4 SCREW
2.5Nm

Reverse the procedure to finish the replacement
Re-tighten all screws to required torque

! Disconnect cables when changing gear tray
Take care to not trap any cables when closing the product

SUPPORT TAG

During installation, remove the label from luminaire glazing and attach inside the column base using cable ties. Luminaire Information can be acquired during future maintenance by scanning the label with mobile devices.

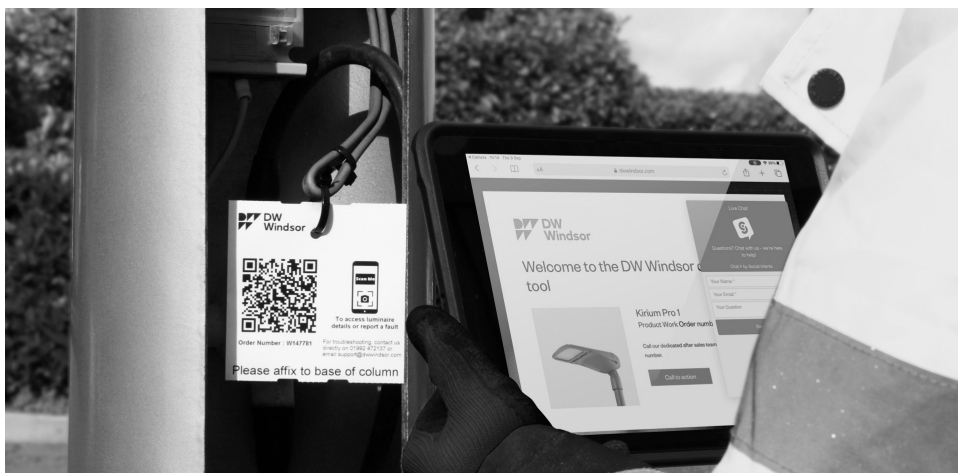

CLEANING

The luminaire is protected against water ingress to IP66.
Sealed design ensures that this rating will be maintained over the full lifetime of the product.



Over time with exposure to the elements, the painted exterior of this luminaire may show signs of weathering such as loss of gloss, chalking and slight colour change. A simple regular clean will minimise the effects of weathering and will remove dirt, grime and other build-up detrimental to all surface coatings.

Use a solution of warm water and non-abrasive, pH neutral detergent solution. Surfaces should be thoroughly rinsed after cleaning to remove all residues. Cleaning should be carried out by hand using a soft cloth or sponge. DO NOT use high pressure water jets or high-pressure cleaners.

CLEANING FREQUENCY

products installed within:

500m of the coast: 3 months

500m – 2000m of the coast or estuary: 6 months

Greater than 2000m of the coast: 12 months

LIGHT SHIELD INSTALLATION

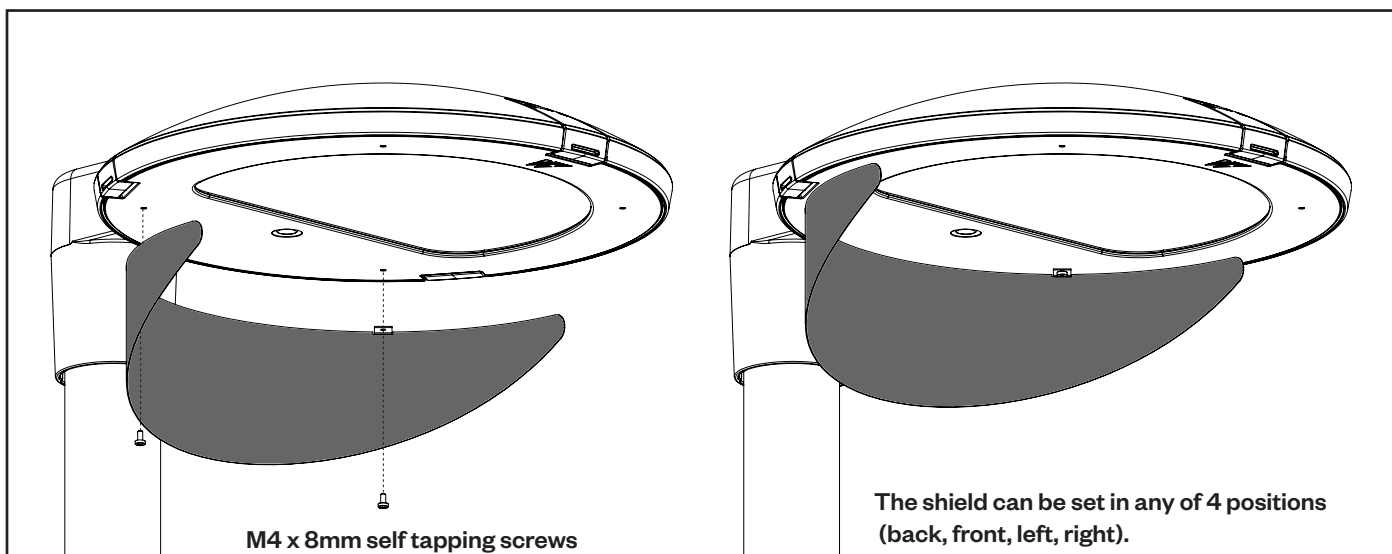

DW Windsor

Pindar Road, Hoddesdon, Hertfordshire, EN11 ODX
T: +44 (0) 1992 474600 | E: info@dwwindsor.com

Due to continuous product development the details within this document are subject to change at any time, please contact us for the most up-to-date information or visit: www.dwwindsor.com