

PULSAR INSTALLATION

LuxEOS 9 Inground VIVID COLOUR & TUNABLE WHITE LED INGROUND FLOOD FOR ARCHITECTURAL LIGHTING

LUXEOS RANGE INGROUND

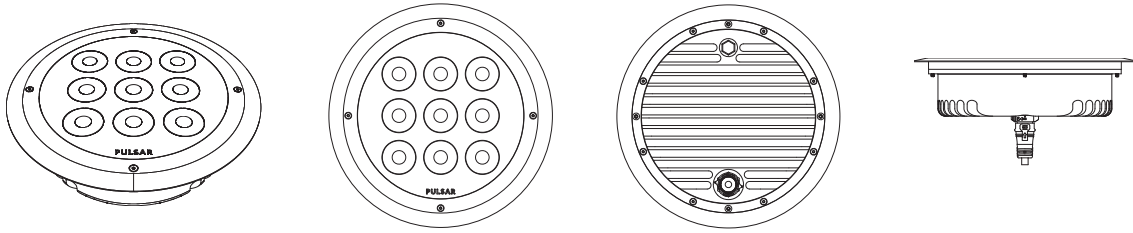

⚠ Important

- LuxEOS luminaires must be installed by a qualified electrician.
- Installation must be carried out in accordance with local and/or national electrical installation codes of practice.
- Isolate the mains supply during installation and whenever subsequently disconnecting or reconnecting the luminaire or luminaire driver.
- Ensure the correct polarity when wiring, if in any doubt please contact Pulsar. Any damage caused to the luminaire or luminaire driver by electrical misconnection will **void the warranty**.
- Unless authorised by Pulsar, field repairs or opening of the luminaire or luminaire driver will **void the warranty**.

WIRING DETAILS

Typical Connections

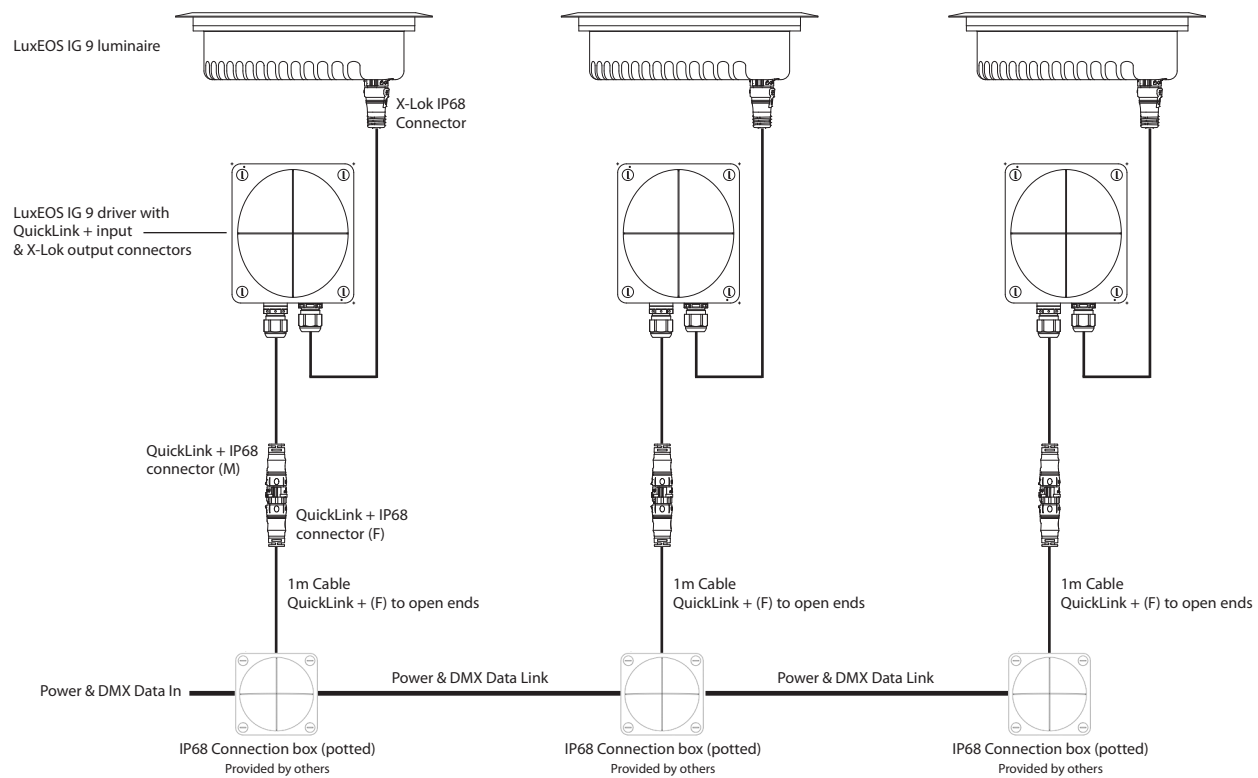

1m Cable - QuickLink + (F) to open ends
(LUXIHWX.XL01.XX.NONE.XXX.XX.XX)



Connection details

- Green - Earth
 - White - Neutral
 - Black - Live
 - Data - Screen
 - White - Data + In
 - Green - Data - In
 - Blue - Data + Out
 - Red - Data - Out
- 120Ω termination resistor must be fitted if the luminaire is last in the DMX data line

The QuickLink + (F) to open end combined power and DMX cable (LUXIHWX.XL01.XX.NONE.XXX.XX.XX) is necessary as part of the first fix solution to enable connections to existing wiring. The bare end of the cable should be connected as shown above using an IP68 installation connection box, care should be taken to separate the mains and control cabling, the female QuickLink + connector can then be plugged into the LuxEOS 9 inground driver to provide power and DMX-RDM control data.

If the driver / cables are installed at an earlier point to the luminaire or if the luminaire is removed, then the power must be disconnected and the supplied blanking cap be fitted to the QuickLink + connector to prevent any ingress to the terminals.

PULSAR

1 Pembroke Avenue, Waterbeach, Cambridge, CB25 9QP
www.pulsarlight.com | sales@pulsarlight.com | +44 (0) 1223 403 500

7650 - L9 IG - INST

1 of 10

LuxEOS 9 Inground VIVID COLOUR & TUNABLE WHITE LED INGROUND FLOOD FOR ARCHITECTURAL LIGHTING

CONTROL

LuxEOS luminaires support DMX512, DMX512:1990, (R2013), ANSI E1.20 – 2010 (DMX with RDM V1.0)

All DMX512 protocols are supported including E1.11 DMX with RDM.

Other protocols may be supported with future software releases or hardware add-ons.

DMX Channel order

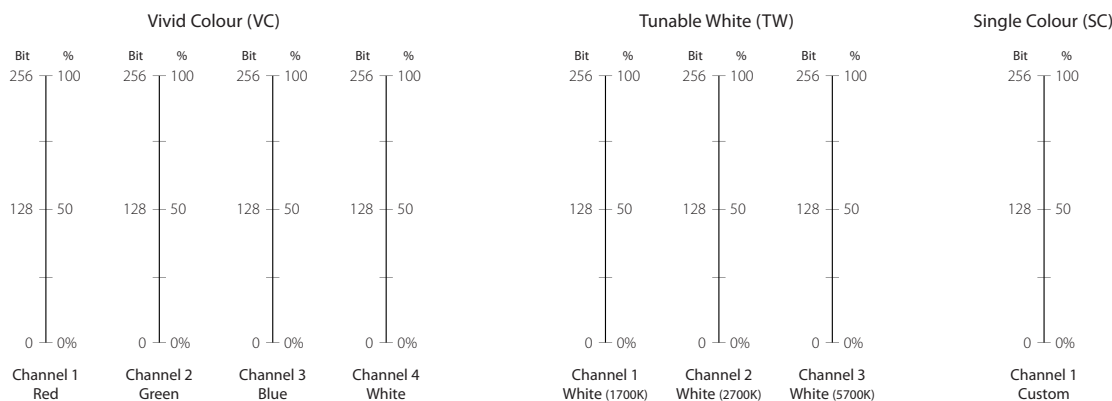

Start addresses are configured externally via RDM over DMX

RDM

The following RDM Parameter I.D'S (PIDS) are supported

Discovery:	0001 – Discovery_Branch_Unique
	0002 – Discovery_Mute
	0003 – Discovery_Unmute
Status:	0020 – Queued_Messages
	0030 – Status_Messages
	0031 – Status_ID_Description
RDM Information:	0050 – Supported_Parameters
Product Information:	0060 – Device_Info
	0070 – Product_Detail_ID_List
	0080 – Device_Model_Description
	0081 – Manufacturer_Label
	0082 – Device_Label (Supporting 32 characters of user text)
	00C0 – Software_Version_Label
DMX512 Setup:	00E0 – DMX_Personality
	00E1 – DMX_Personality_Description
	00F0 – DMX_Start_Address
	0120 – Slot_Info
	0121 – Slot_Description
Sensors:	0200 – Sensor_Definition
	0201 – Sensor_Value
Power/Lamp Settings:	0400 – Device_Hours
Control:	1000 – Identify_Device

LuxEOS 9 Inground VIVID COLOUR & TUNABLE WHITE

LED INGROUND FLOOD FOR ARCHITECTURAL LIGHTING

PRODUCT DRAWINGS - LUMINAIRE
(All dimensions in mm)

Top view

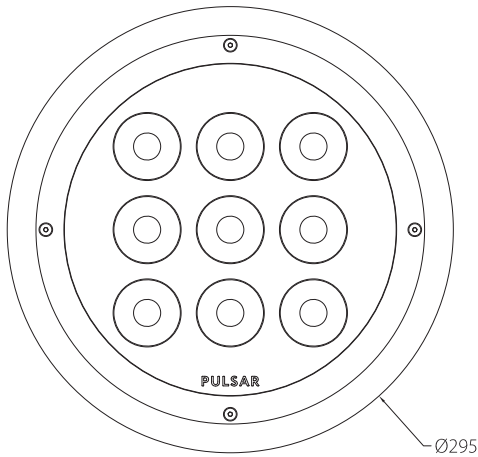

Rear View

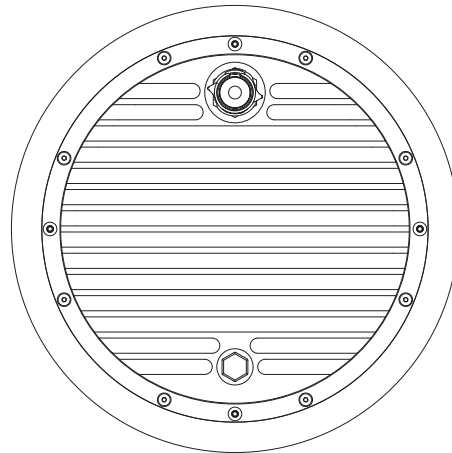

Front view

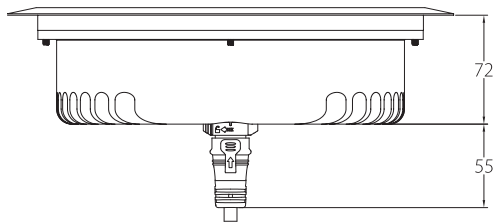

Perspective view

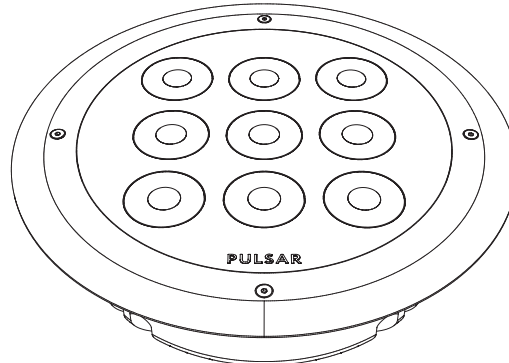

Side view

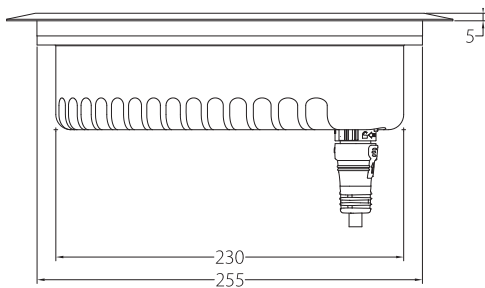

Weight
LuxEOS 9 Inground - 3.9 kgs
Dimensions (with connector)
295mm (Dia) x 132mm (D)

LuxEOS 9 Inground VIVID COLOUR & TUNABLE WHITE

LED INGROUND FLOOD FOR ARCHITECTURAL LIGHTING

PRODUCT DRAWINGS - LUMINAIRE DRIVER

(All dimensions in mm)

Enclosure
Front view

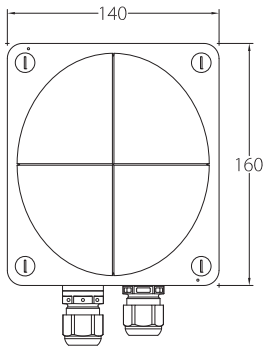

Side view

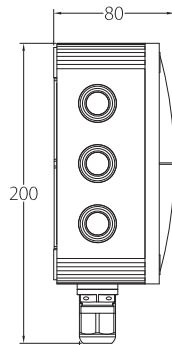

Top view

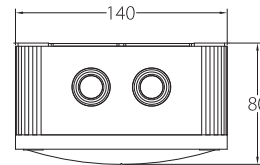

Driver enclosure with cables

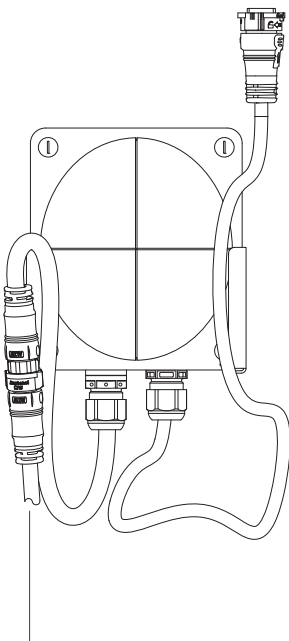

QuickLink + connection input cable
Mains / DMX input & through connections

Luminaire & driver

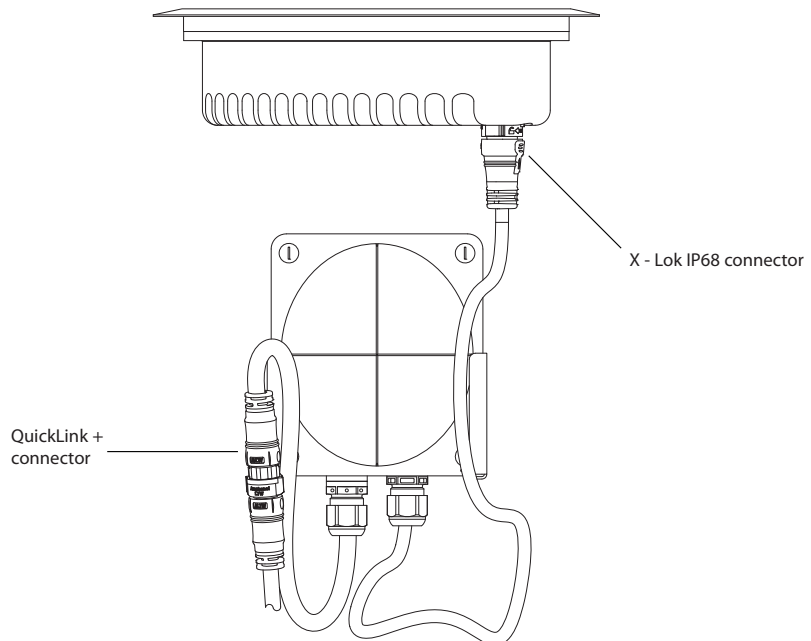

Weight

Driver with cables - 1.1 kgs

Dimensions (enclosure)

140mm (W) x 160mm (H) x 80mm (D)

LuxEOS 9 Inground VIVID COLOUR & TUNABLE WHITE LED INGROUND FLOOD FOR ARCHITECTURAL LIGHTING

PRODUCT DRAWINGS - GROUND MOUNT KIT
(All dimensions in mm)

Ground Mount
Front & Rear view

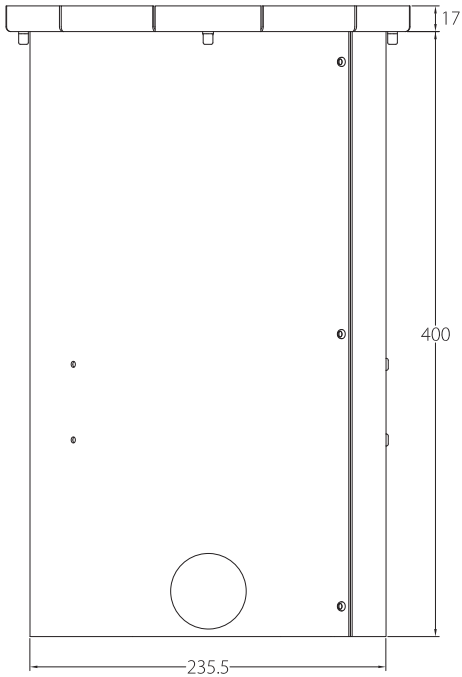

Left & Right view

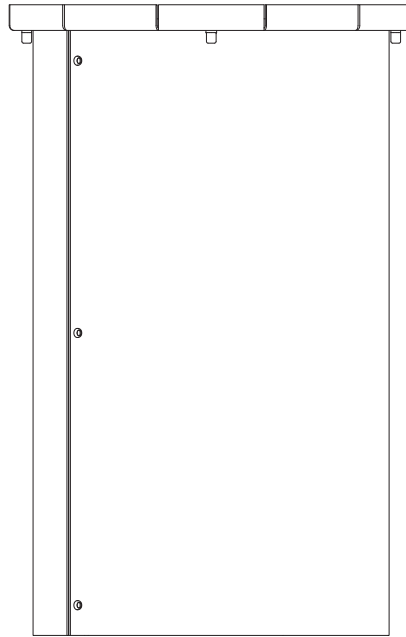

Top view

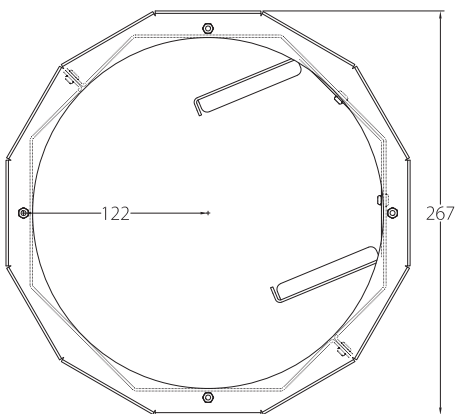

Perspective view

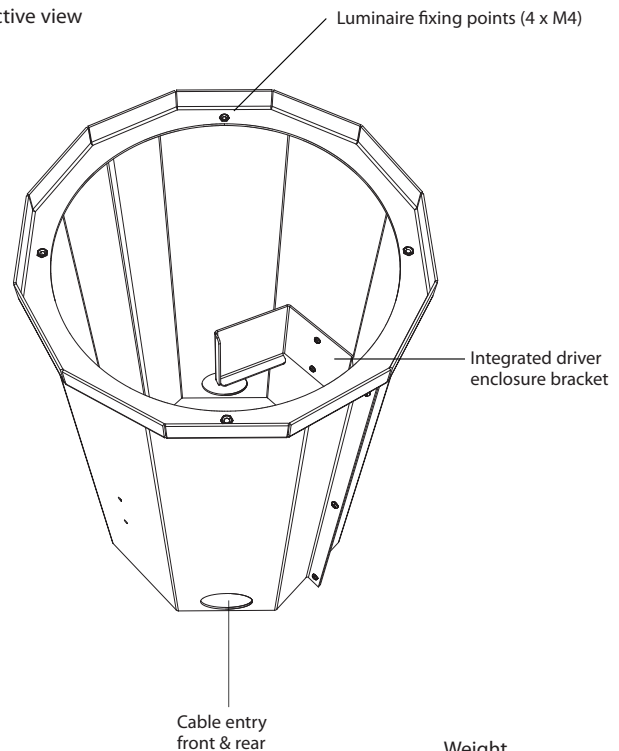

Weight
Ground Mount - 4.5 kgs

LuxEOS 9 Inground VIVID COLOUR & TUNABLE WHITE

LED INGROUND FLOOD FOR ARCHITECTURAL LIGHTING

GROUND MOUNT INSTALLATION

⚠ Important

- The ground mount **must** be supported beneath the edge of the top rim by at least 150mm of hard material (e.g. concrete).
- Adequate drainage **must** be provided, failure to do so will **void the warranty**.
- To test the drainage of the ground mount, ensure that it drains at **least** as fast as it fills up.
- The ground mount **must not** be installed in such a way that the luminaire is recessed and can become submerged.
- The ground mount **must not** be installed in such a way that the fixture could become a trip hazard.
- Installations on soft or marshy ground should have reinforcement bars beneath the underside of the ground mount and have adequate drainage.

1. PREPARATION

Ground Works

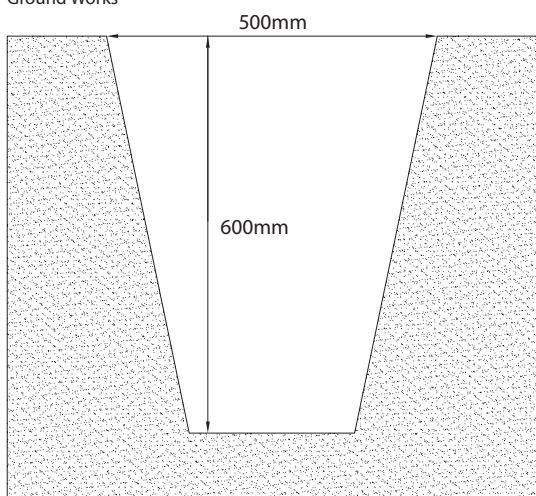

The hole for the ground mount should be 600mm deep to allow for at least 200mm of hard surface or drainage material underneath the ground mount. The hole should be 500mm wide at the opening.

Ground works sealing plugs

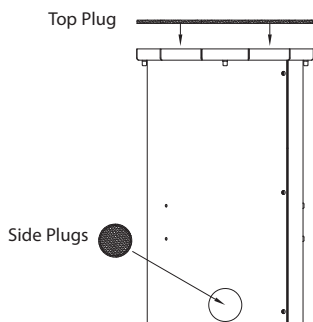

Fit the ground works sealing plugs included with the kit into the top opening and lower cable entry points to provide a temporary seal from wet concrete and drainage material entering the ground mount vessel.

2. DRAINAGE & STABILITY

Mounting Examples

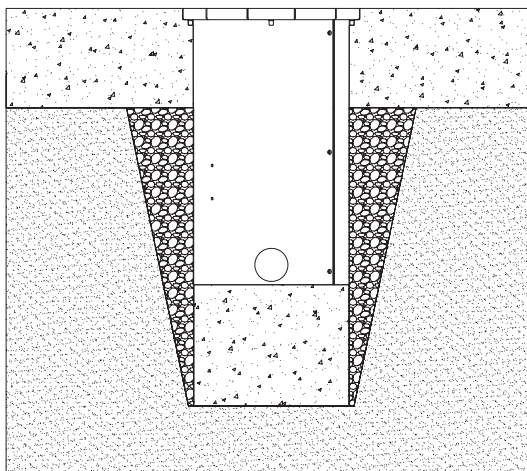

Example 1. The ground mount is seated on a hard concrete base, and the sides are filled with drainage material. Concrete is used to fill to a level flush with the top of the ground mount.

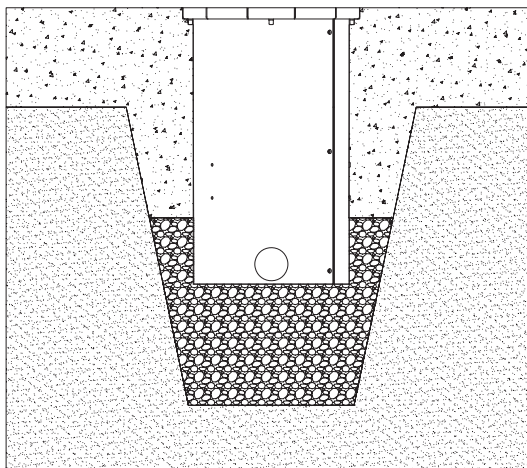

Example 2. The bottom of the ground mount is seated on drainage material, and held in place with concrete to a level flush with the top of the ground mount.

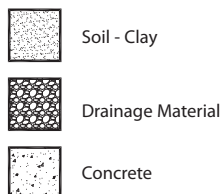

LuxEOS 9 Inground VIVID COLOUR & TUNABLE WHITE LED INGROUND FLOOD FOR ARCHITECTURAL LIGHTING

LUMINAIRE & LUMINAIRE DRIVER - GROUND MOUNT INSTALLATION

⚠ Important

- Installation must be carried out in accordance with local and/or national Installation codes and regulations.
- Ensure that the ground mount is separately electrically earthed to ground.
- The LuxEOS 9 Inground luminaire should only be used with the supplied driver, connecting the luminaire to another driver will **void the warranty**.
- Do not operate in locations where the ambient temperature will exceed 50°C.
- Ensure that air can freely flow over the luminaire heat sink.
- Use only with attachments and accessories specified by Pulsar.
- Use only with the Pulsar ground mount as specified in this instruction leaflet.

Installation of the luminaire & driver into a pre-installed ground mount

1. Install the driver into the ground mount

The ground mount has an internal bracket to fix and secure the LuxEOS 9 inground driver. Slot the driver into the bracket ensuring that it is firmly held in place.

2. Install and connect the power and DMX to the driver.

Hardwire the QuickLink + combined power and control input cable ensuring that connections are made in a suitable sealed and potted IP68 enclosure. Once installed, connect the driver via the QuickLink + Power & DMX connectors ensuring that the connectors **click** and lock into place.

3. Connect the luminaire

Connect the luminaire to the driver via the X-Lok connector, to connect, line up the arrows and push until the connector **clicks** into place.

4. Install the luminaire into the ground mount

Secure the luminaire to the ground mount with four M4 fixing screws through the holes on the front bezel.

5. Test the luminaire

Ensure that all connections are secure correctly connected and sealed, then power up and test the luminaire.

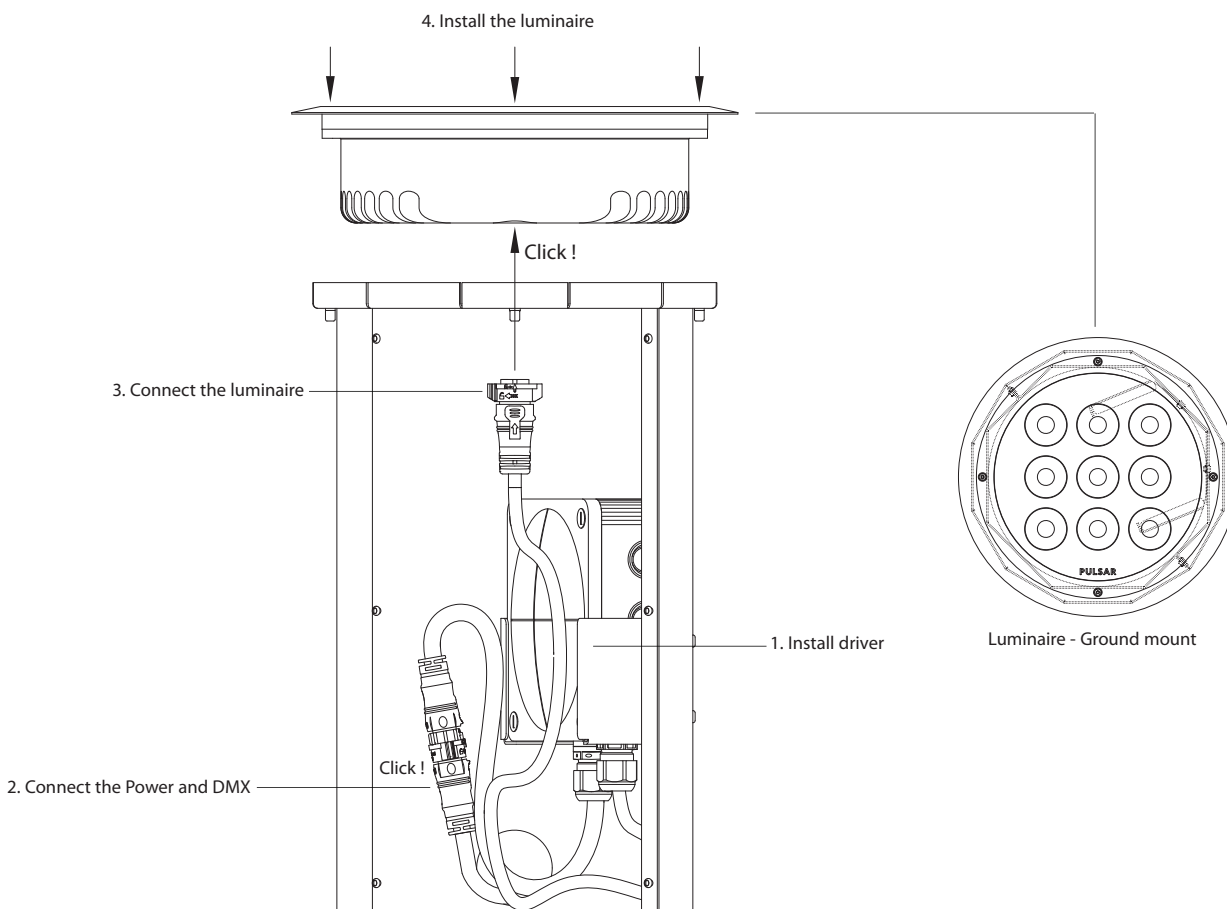

LuxEOS 9 Inground VIVID COLOUR & TUNABLE WHITE LED INGROUND FLOOD FOR ARCHITECTURAL LIGHTING

LUMINAIRE - DRIVER - GROUND MOUNT

Installed - Luminaire , Driver & Ground Mount
(Cutaway view - Front inground panel omitted for clarity)

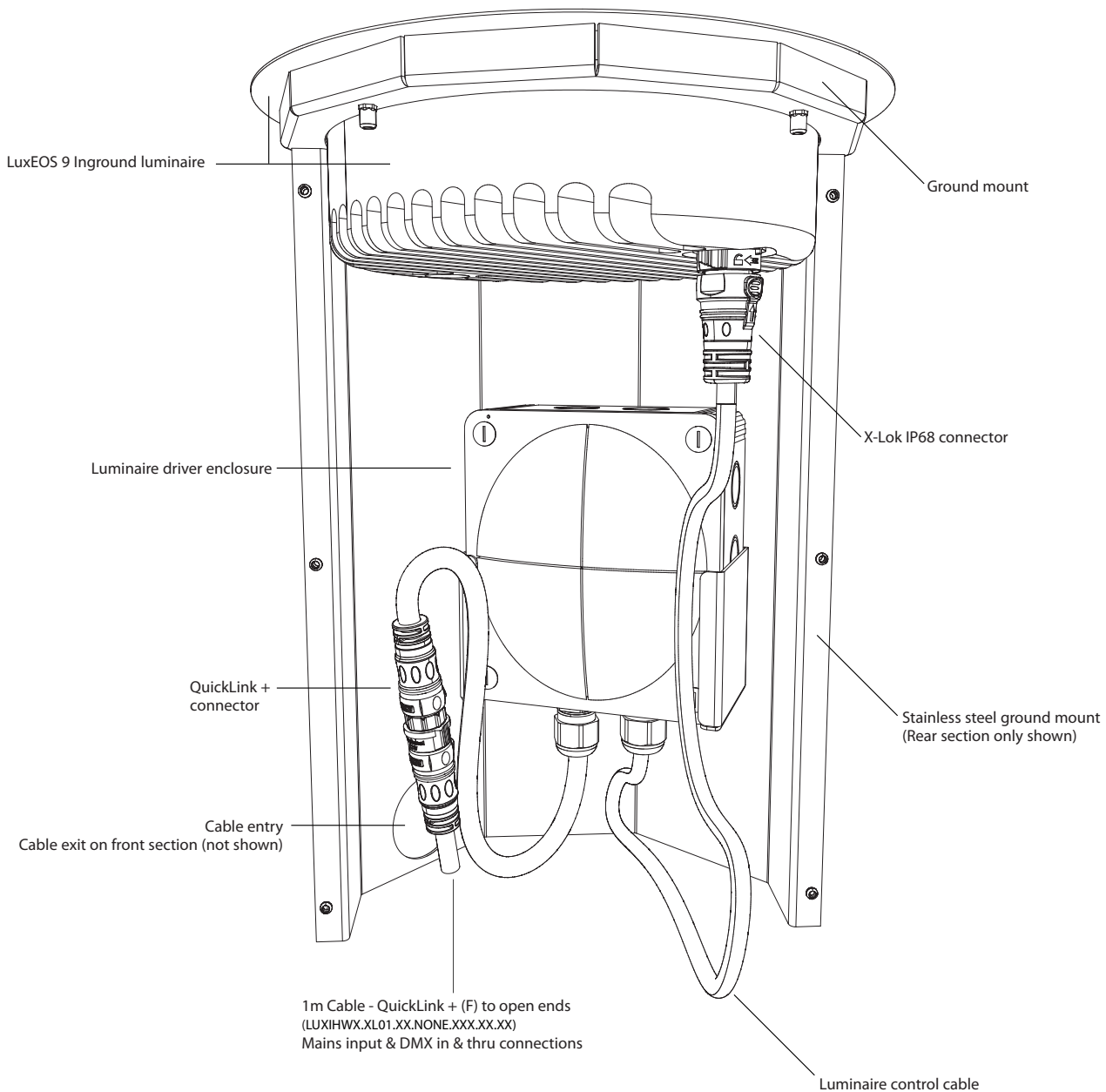

⚠ Important

1m Cable - QuickLink + (F) to open ends (LUXIHWX.XL01.XX.NONE.XXX.XX.XX)
This must be wired into a suitable potted IP68 connection box, taking care to separate the mains voltage and low voltage signal cables.
The ground mount chassis should be separately electrically earthed to ground

LuxEOS 9 Inground VIVID COLOUR & TUNABLE WHITE

LED INGROUND FLOOD FOR ARCHITECTURAL LIGHTING

HBS FILTERS

The LuxEOS 9 Inground is fitted with HBS (holographic beam shaping filters) for shaping and modifying the light output. HBS takes the form of highly efficient diffuser sheets that are pre installed internally at manufacture. The standard fitted fixed beam angles are:- Conical 10°, 20°, 40°, 80° and Elliptical 10° x 60° or 60° x 10°.

In addition to the standard beam angles, an additional HBS filter can be factory fitted that will tilt the light beam to a fixed angle, this is a very useful feature for when the luminaire is placed away from the surface to be lit. The tilt filters have an additional feature which allows them be rotated internally within the luminaire using our unique magnetic adjustment system.

HBS TILT FILTERS

Fixed tilt filters

The following HBS tilt filter angles are available.

Tilt 8 - 8° offset tilt (20° x 40° elliptical) when used with the native 10° beam)

Tilt 20 - 20° offset tilt (10° x 10° conical) when used with the native 10° beam)

Tilt 8

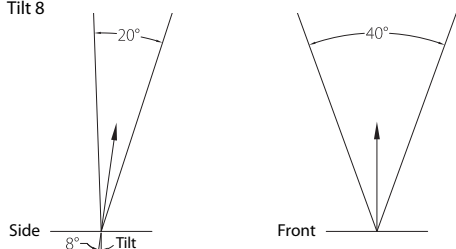

Tilt 20

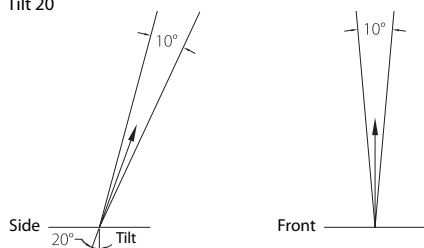

Internal magnet location

To adjust the tilt rotation, an internal magnet is attached to the HBS tilt offset filter within the luminaire in the position as shown below.

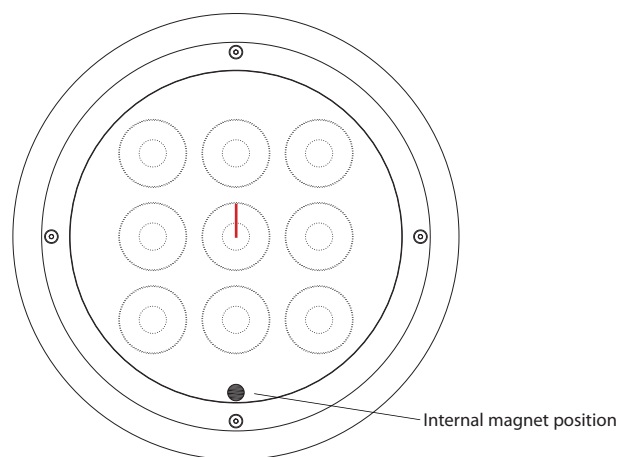

Direction of tilt rotation indicator

The tilt filters have an inscribed direction line which is located in the centre of the luminaire. The direction line is a useful aid for locating, rotating and aligning the beam to the surface or object that is being illuminated.

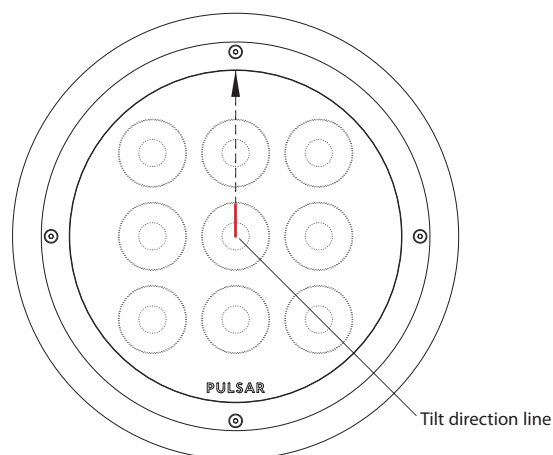

Adjusting the tilt rotation angle with the steering magnet

Place the supplied steering magnet on the glass to pick up the internal magnet. Once attached, drag the steering magnet around the perimeter of the glass to set the tilt rotation to the desired angle.

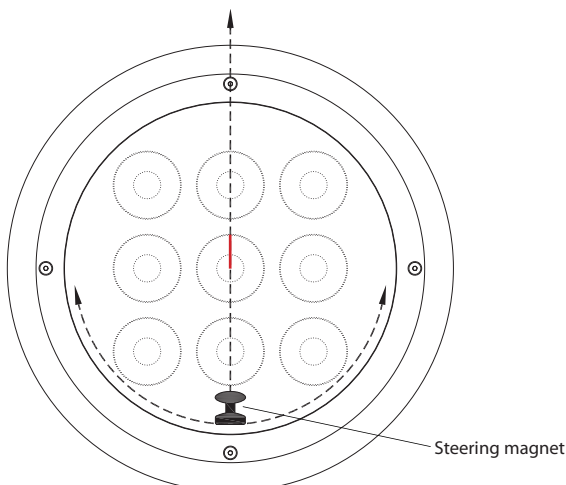

⚠ Important

LuxEOS 9 inground luminaires are fitted with HBS filters and sealed on manufacture. To change the HBS filters, the luminaire **must** be returned to PULSAR for upgrade. **Opening the luminaire will void the warranty.**

LuxEOS 9 Inground VIVID COLOUR & TUNABLE WHITE LED INGROUND FLOOD FOR ARCHITECTURAL LIGHTING

ADDITIONAL INFORMATION

Mains Supply Cable Colours (Harmonised)

Green/Yellow	Earth - Ground
Brown	Live Phase
Blue	Neutral

DMX Cable Colours (Pulsar)

White	DMX +
Blue	DMX -
Shield	Screen

QuickLINK+ Cable Colours (Power)

Green	Earth - Ground
Black	Live Phase
White	Neutral

QuickLINK+ Cable Colours (Data in)

White	DMX +
Green	DMX -
Shield	Screen

QuickLINK+ Cable Colours (Data through)

Red	DMX +
Blue	DMX -
Shield	Screen

Power Requirements

LuxEOS Flood 9 Inground 120 -277V AC @ 50/60Hz 50W

Portable Appliance Testing

LuxEOS luminaires may be safely earth bond and insulation tested (500V).

Product Weights

LuxEOS 9 Inground Luminaire	3.9 kgs
LuxEOS 9 Inground Driver	1.1kgs
LuxEOS 9 Inground Ground Mount	4.5kgs

Mechanical Ratings

Ingress Protection IP67	LuxEOS 9 Inground luminaire & driver
Impact Protection IK10	LuxEOS 9 Inground luminaire
Static Load 3000kgs	LuxEOS 9 Inground luminaire

Maintenance

LuxEOS luminaires should be regularly tested and inspected, and as part of this checked for the build up of external moss and debris which can reduce the light output. If cleaning is required, then a mild water based detergent should be used, care should be taken to avoid the use of harsh solvent based cleaning materials as this could result in damage to the luminaire. Under no circumstances should pressure washers be used for cleaning.

The light source contained in this luminaire shall only be replaced by Pulsar or an authorised service agent or a similar qualified person.

Standards

LuxEOS luminaires conform to the following standards and certification.



UKCA



European CE



RoHS



WEEE

Warranty

Five years from the date of original purchase.

The warranty covers defects in manufacturing workmanship and materials. It is limited to parts and labour.

The warranty becomes void if the product is :-

- A Misused.
- B Not used in accordance with the instructions.
- C The cable connections are not made according to our instructions if the unit is used in damp or wet environments.
- D Repairs are made by unauthorised persons.
- E The serial number label has been removed or defaced.

Pulsar's maximum liability shall not exceed the price paid for the product.

In the unlikely event of a fault occurring, do not use without repair, return the product, with a description of the fault, to your supplier or direct to Pulsar for immediate attention.

Full warranty details are available on request or from our website at www.pulsarlight.com.

As part of our commitment to continuous improvement PULSAR may change the specifications of its products without prior notification or public announcement.

All descriptions, illustrations, drawings and specifications in this publication present only general particulars and shall not form part of any contract.

Please visit our website for the most up to date information.